

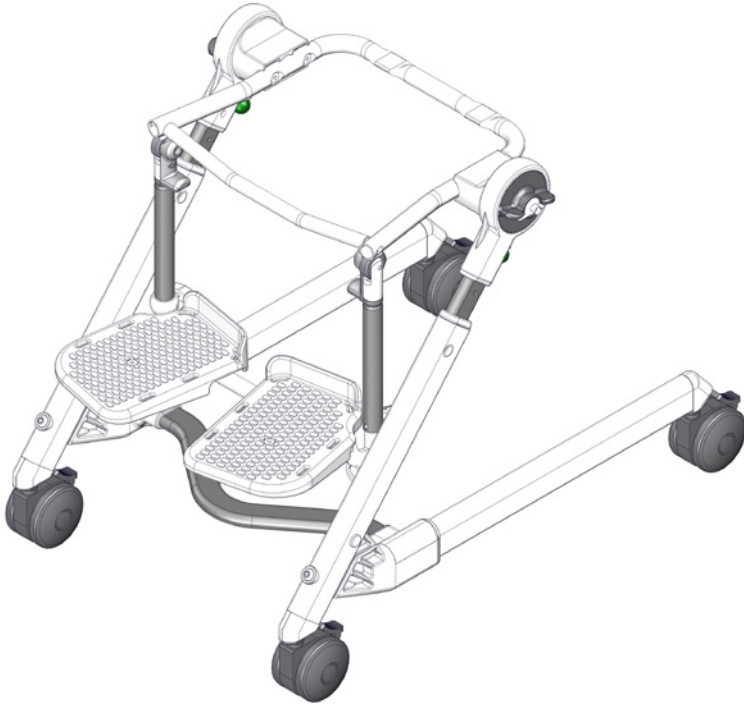

max 540 mm (21")



max 70 kg (154 lb)



Flamingo Frame User Guide

EN 12182

2020-05-rev.05

	3	ENGLISH DEUTSCH	23 - 25 26 - 28
	4	NEDERLANDS DANSK	29 - 31 32 - 34
	5	NORSK SVENSKA	35 - 37 38 - 40
	6	SUOMI ESPAÑOL	41 - 43 44 - 46
	7	FRANÇAIS ITALIANO	47 - 49 50 - 52
	8	PORTUGUÊS PORTUGUÊS DO BRASIL	53 - 55 56 - 58
	9	РОССИЯ POLSKI	59 - 61 62 - 64
	10	ČESKY 中國	65 - 67 68 - 70
	11	日本 ΕΛΛΗΝΙΚΗ	71 - 73 74 - 76
	12		
	13		
	14		
	15		
	16 - 19		
mm (inch)	20		
	21 - 22		

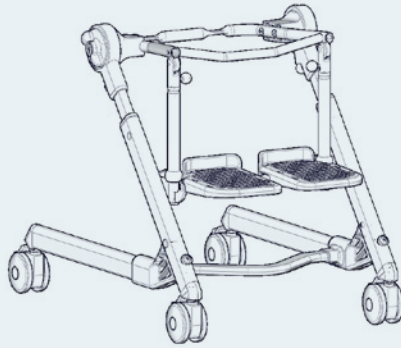

Flamingo frame 1

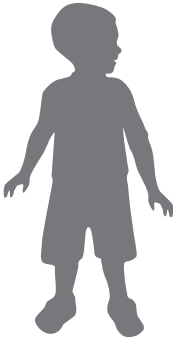

<35 kg
<77 lb

Flamingo frame 2

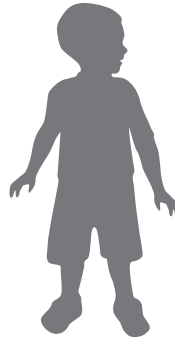

<50 kg
<110 lb

Flamingo frame 3

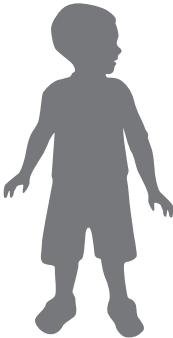

<60 kg
<132 lb

Flamingo frame 4

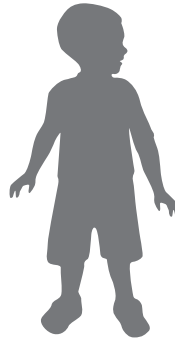

<70 kg
<154 lb

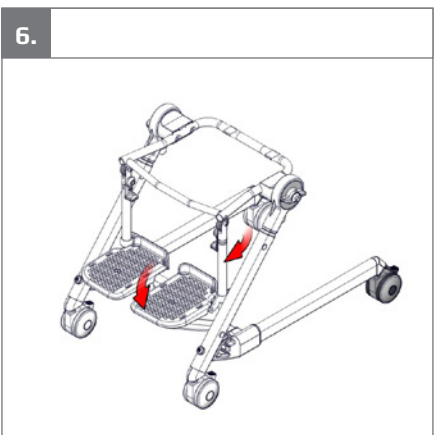
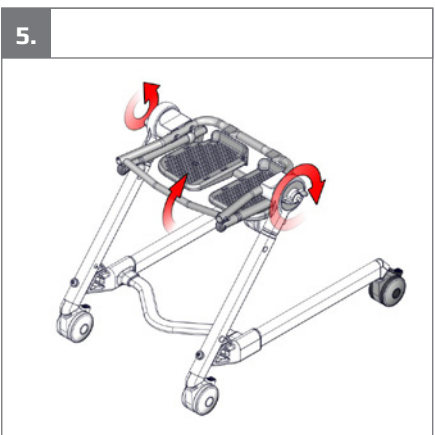
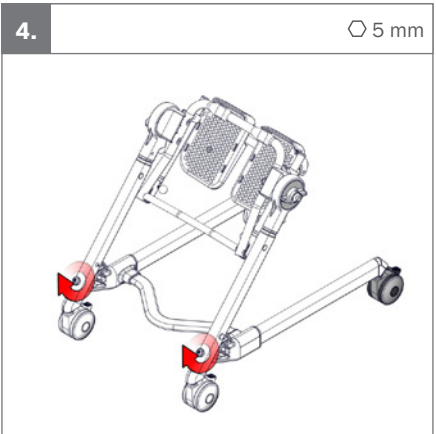
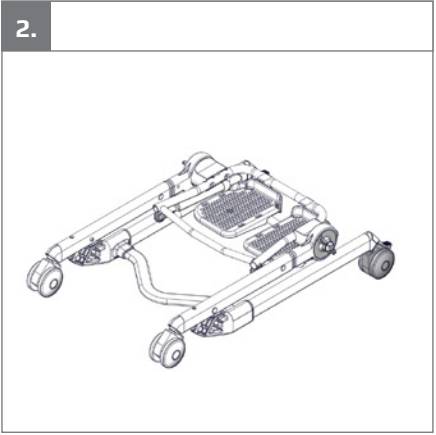
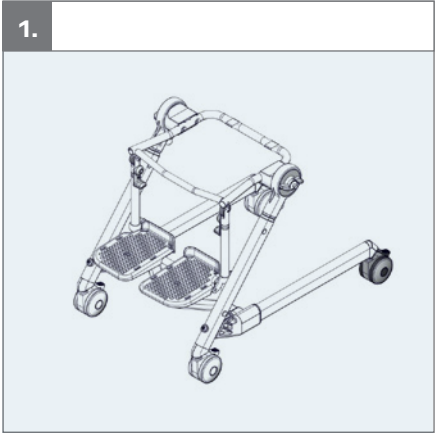



1.

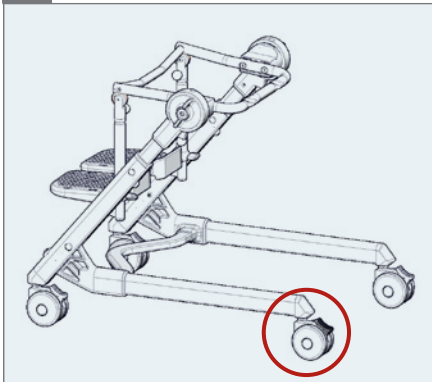

2.

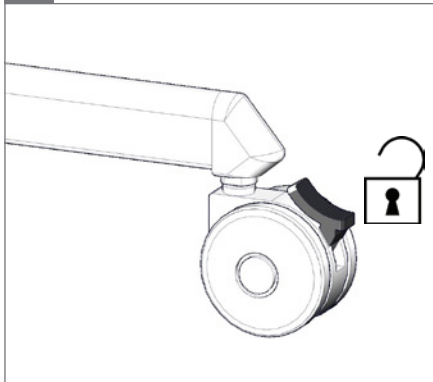

3.

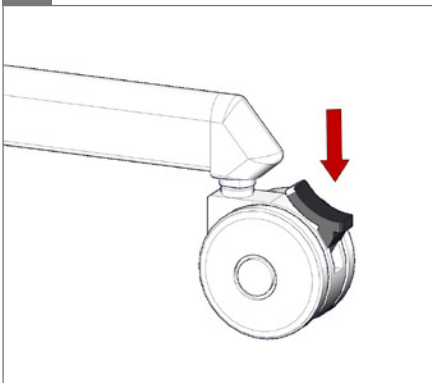

4.

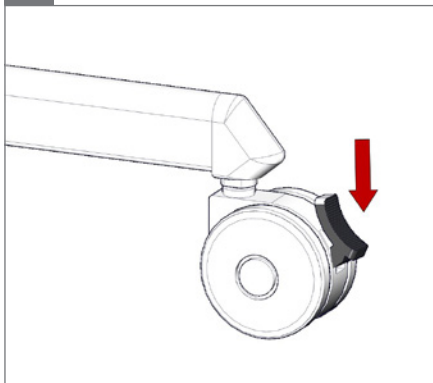

5.

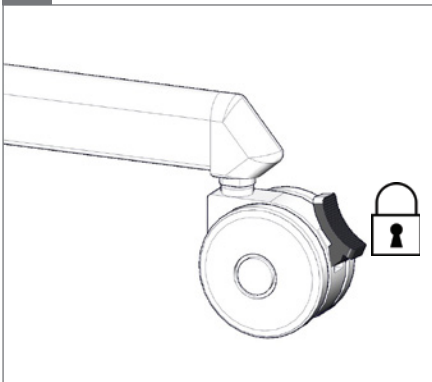

6.

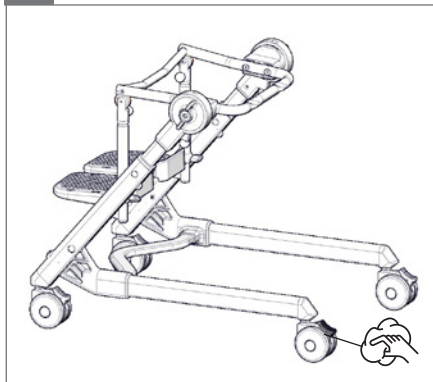

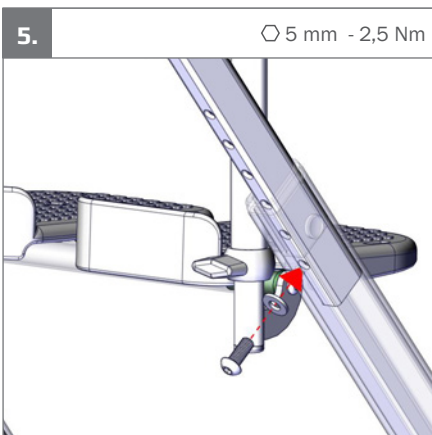
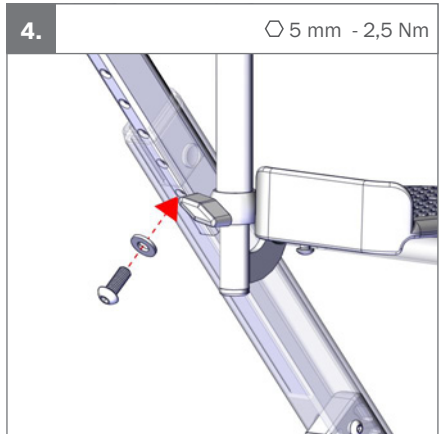
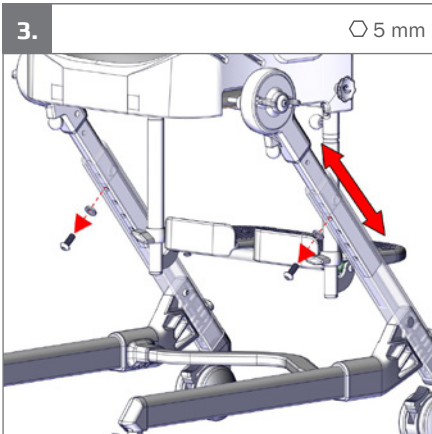
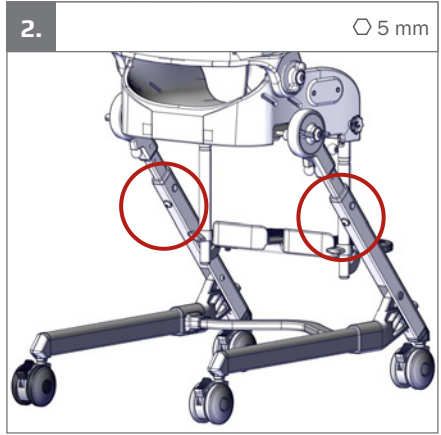
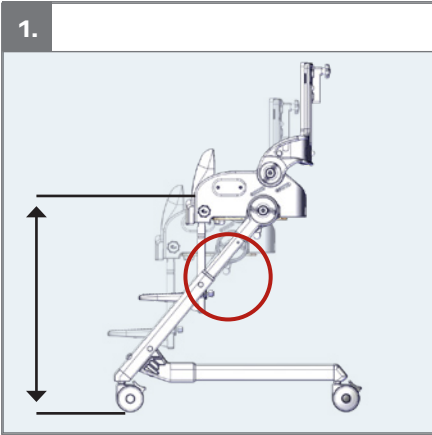

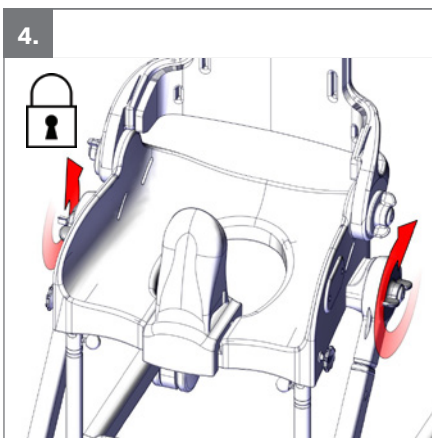
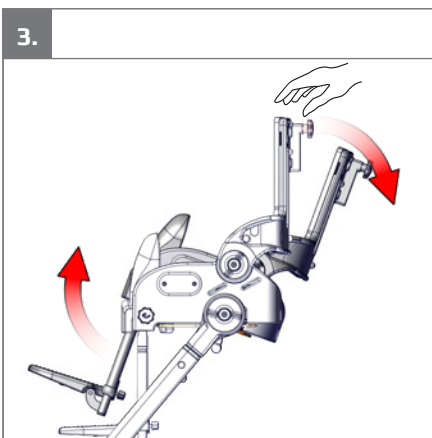
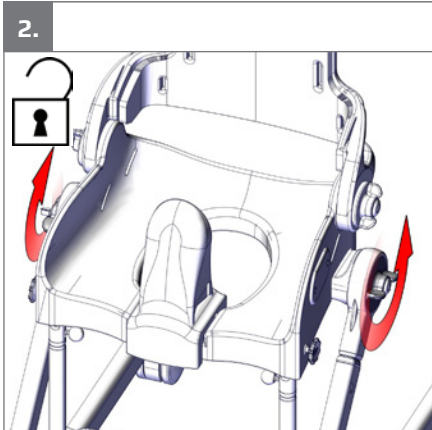
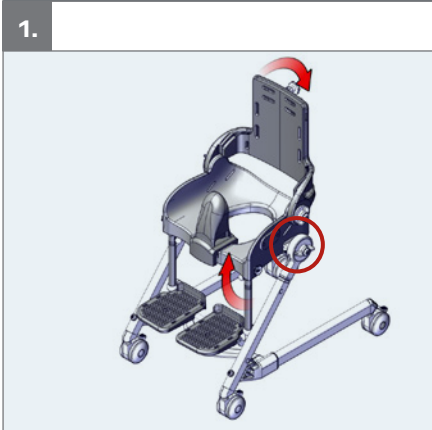

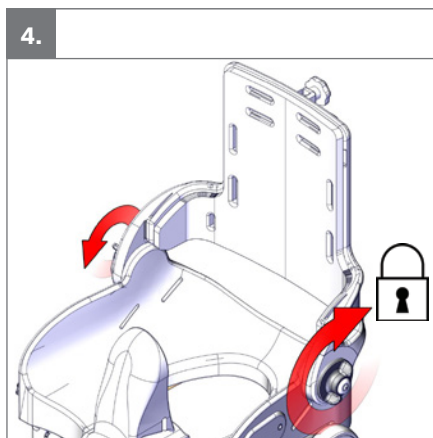
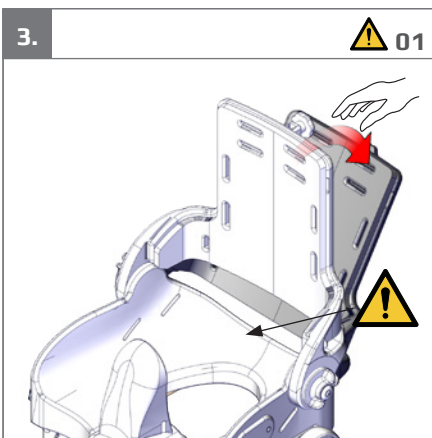
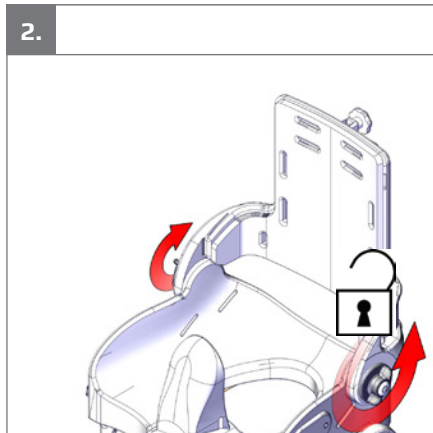



1.

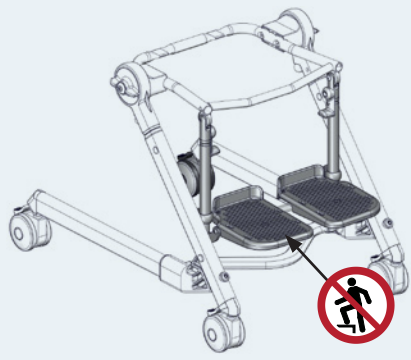

2.

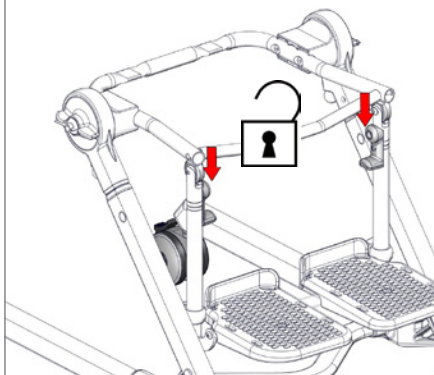

3

90° - 60°

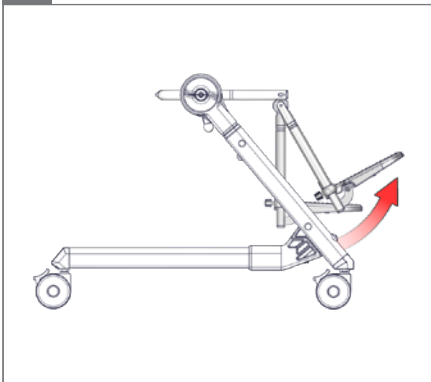

4.

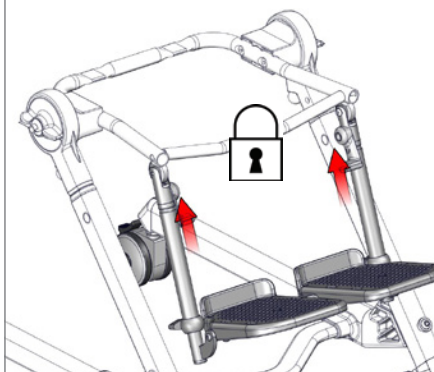



1.



2.

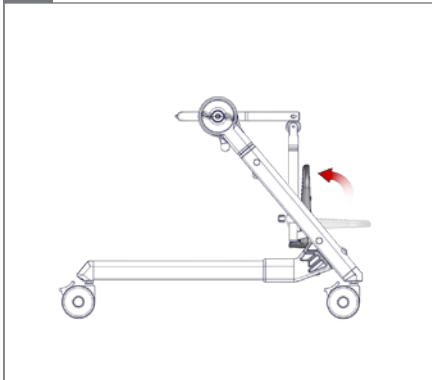

3.

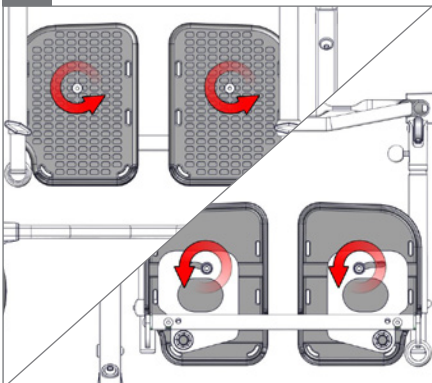
○ 4 mm  10 mm

4.

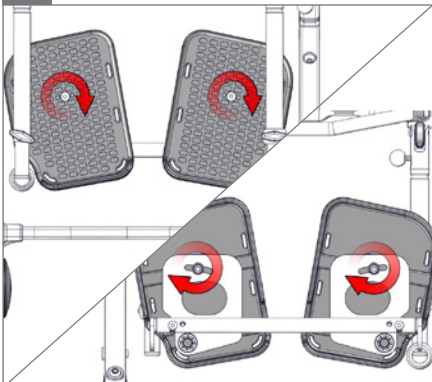

5.

○ 4 mm  10 mm - 2,5 Nm

6.





1.

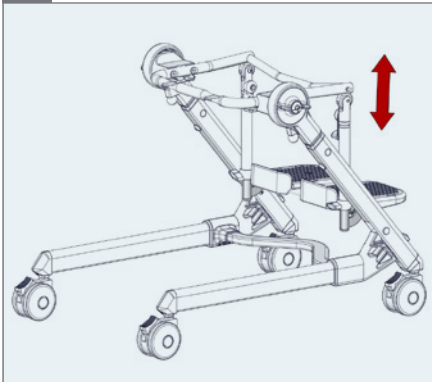

2.

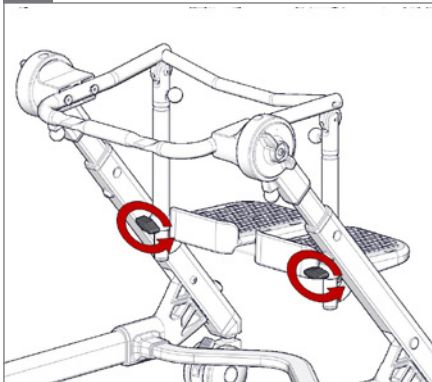

3.

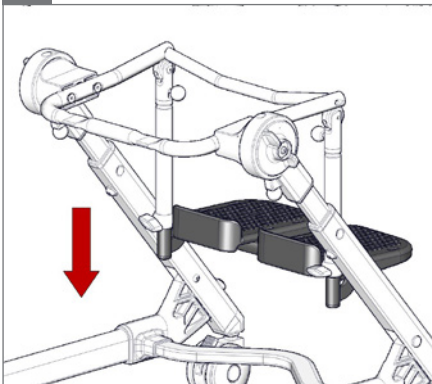

4.

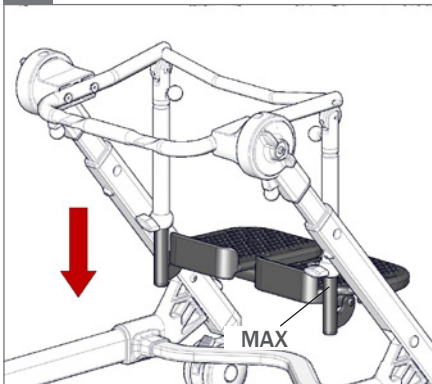

5.

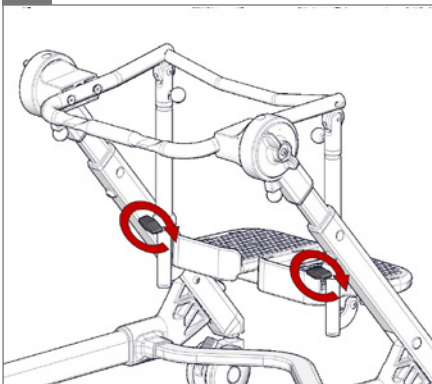

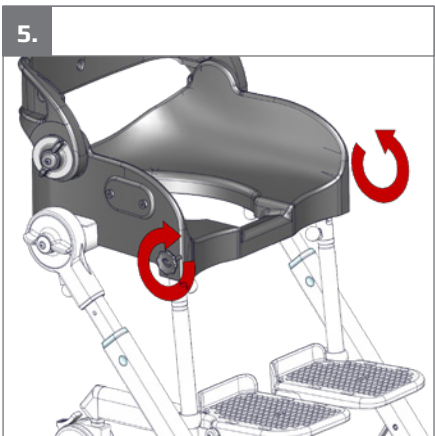
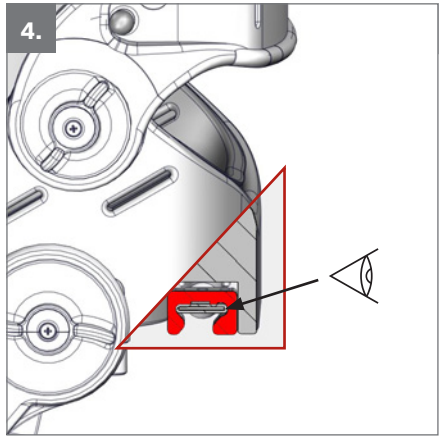
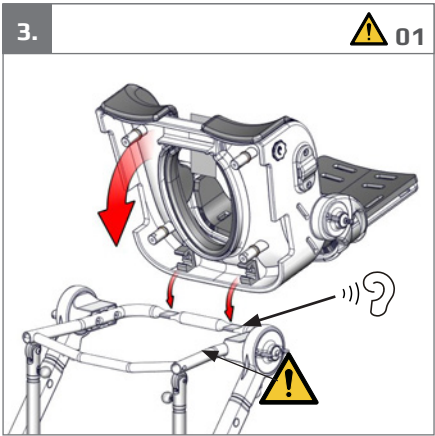

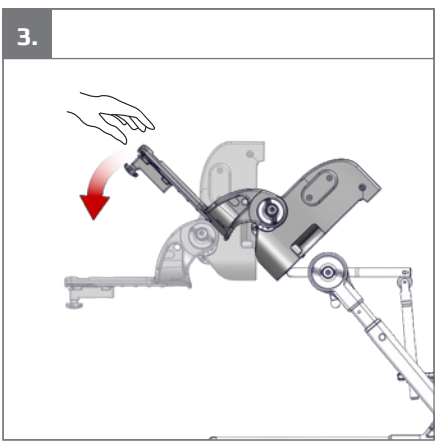
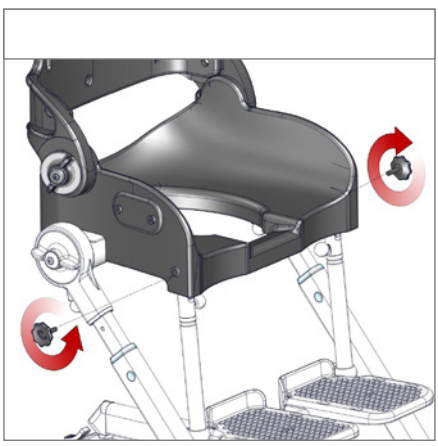



1.

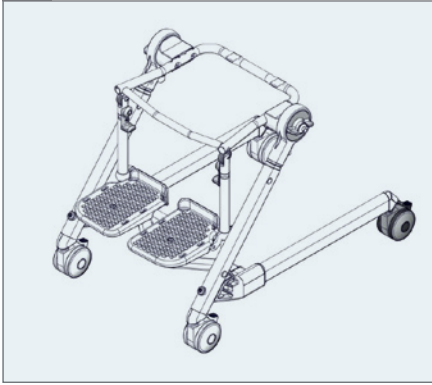

2.

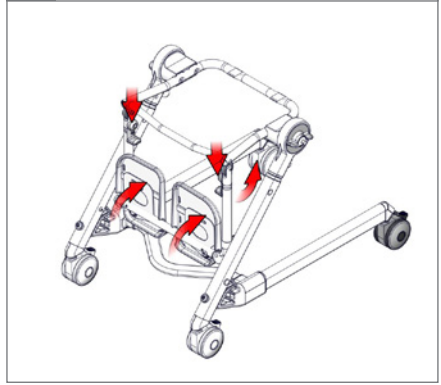

3.

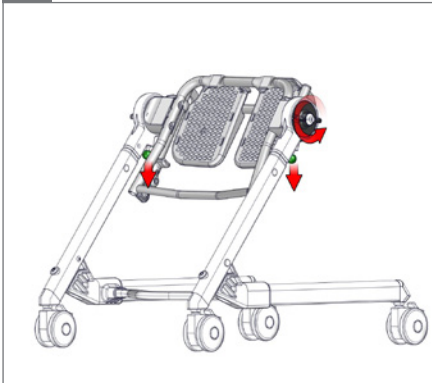

4.

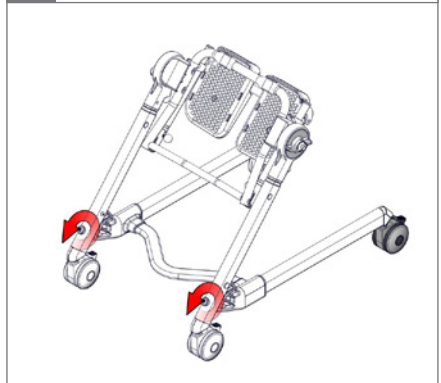

5.

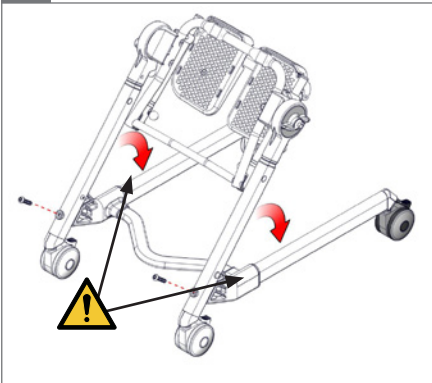

6.

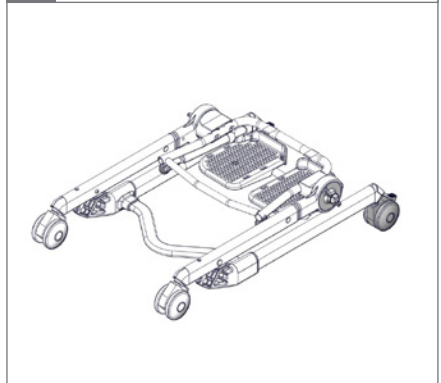

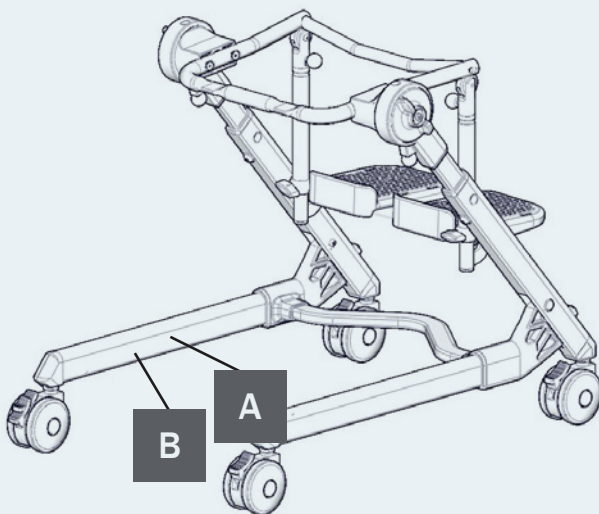

A

R82[®]

Parallelvej 3
DK-8751 Gedved
WWW.R82.ORG

Made in XXXXXXXX YYYY-MM-DD

B

Product: xxxx - Size x
Art. no.: xxxxxxxx Max user mass xxx kg
 XXXXXXXX
DMR ver.: XXXX Mass device: xxx kg
Max rated load: xxx kg

(xx)xxxxxxxxxxxxxxxxxx(xx)xxxxxxxx(xx)xxxxxx

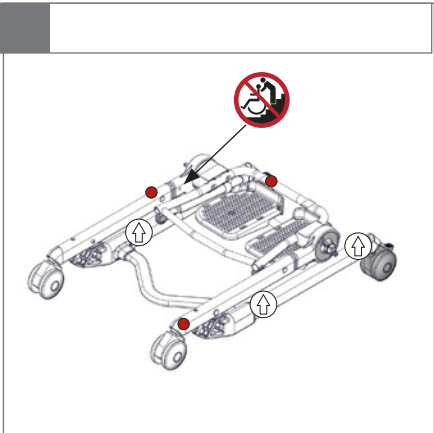

**EN:** For indoor use**NO:** For innendørs bruk**FR:** Utilisation intérieure**RU:** Для использования в помещении**JP:** 屋内使用**DE:** Für den Innengebrauch**SV:** För inomhusbruk**IT:** Per uso interno**PL:** Do użytku wewnątrz**GR:** Κατάλληλο για εσωτερική χρήση**NL:** Voor binnenhuis gebruik**FIN:** Sisäkäyttöön**PT:** Para utilização em interiores**CZ:** Pro vnitřní používání**DK:** Til indendørs brug**ES:** Para uso en interiores**BR:** Para uso interno**SN:** 适用于室内使用**EN:** Consult instructions. The latest version of the instructions is always available on the R82 website and can be printed in larger sizes**NO:** Sjekk bruksanvisning på nett. Nyeste versjon av bruksanvisningen er alltid tilgjengelig, og kan skrives ut fra R82 nettsted**FR:** Se reporter aux instructions / consulter les instructions. La version la plus récente est toujours disponible et peut être imprimée dans un grand format à partir du site internet de R82**RU:** Прочитайте инструкции. Новейшая версия инструкций всегда доступна на веб-сайте компании R82 и может быть распечатана в увеличенном размере**JP:** 説明をお読みください。この説明の最新バージョンは、R82のWebサイトからいつでもご利用いただけます。大きなサイズで印刷することができます**DE:** Bedienungsanleitung. Die neueste Version dieser Anleitung ist auf der R82 Internetseite verfügbar und steht zum Download bzw. Ausdruck zur Verfügung**SV:** Se anvisningarna. Den senaste versionen av anvisningarna finns alltid tillgänglig och kan skrivas ut i större storlek från R82:s webbplats**IT:** Leggere le istruzioni. Le ultime versioni dei manuali di istruzione sono sempre disponibili sul sito web R82 e possono essere stampate in dimensioni maggiori**PL:** Zapoznanie się z instrukcją. Najnowsze wersje instrukcji obsługi są dostępne na stronie internetowej R82 i można je wydrukować w większych formatach**GR:** Διαβάστε τις οδηγίες. Οι τελευταίες εκδόσεις των οδηγιών είναι πάντοτε διαθέσιμες στην ιστοσελίδα της R82 και μπορούν να εκτυπωθούν σε μεγαλύτερα μεγέθη**NL:** Raadpleeg de instructies. De meest recente versie van alle instructies zijn altijd beschikbaar en kunnen worden afgedrukt in de groter formaat vanaf de R82 website**FIN:** Lisäohjeet. Viimeisin versio kaikista ohjeista on aina saatavilla ja tulostettavissa R82 nettisivustolta**PT:** Leia as instruções. As últimas versões das instruções estão sempre disponíveis na página da R82 na internet e podem ser impressas em tamanhos maiores**CZ:** Poradenství a instrukce. Nejaktuálnější verze všech instrukcí je vždy dostupná na webu R82, odkud se dá stáhnout a i vytisknout**DK:** Se vejledning. Den seneste version af denne vejledning er altid tilgængelig og kan udskrives i større størrelser fra R82 hjemmeside**ES:** Consulte las instrucciones. La última versión de todas las instrucciones está siempre disponible y se puede imprimir en tamaños superiores desde la página web de R82**BR:** Leia as instruções. As versões mais recentes das instruções sempre encontram-se disponíveis no site da R82 e podem ser impressas em tamanhos maiores**SN:** 参考说明。所有说明的最新版本都能够R82网络上下载或打印**EN:** Correct lifting point**NO:** Riktig løftpunkt**FR:** Point de levée approprié**RU:** Надлежащая точка подъема**JP:** リフティング・ポイントの修正**DE:** Korrekter Hebe punkt**SV:** Korrekt lyftpunkt**IT:** Punto di sollevamento corretto**PL:** Prawidłowy punkt podnoszenia**GR:** Σωστό σημείο λαβής**NL:** Correcte techniek van optillen**FIN:** Oikea nostopiste**PT:** Corrija o ponto de elevação**CZ:** Správný zvedací bod**DK:** Korrekt løftepunkt**ES:** Punto de elevación correcto**BR:** Ponto de elevação correto**SN:** 请调整吊点



EN: Warning: This symbol appears in the User Guide along with a number referring to the instructions below. It draws attention to situations where the product or the user or carer's safety may be in danger
01 = Entrapment Hazards
02 = Tilting Hazards
03 = Transportation in motor vehicles
05 = Squeezing Hazard

NO: Advarsel: Dette symbolet blir vist i brukerveiledningen sammen med et tall som henviser til instruksjonene under. Det gjør oppmerksom på situasjoner der produktet eller brukernes/omsorgryterens sikkerhet kan være truet
01 = Fare for å bli sittende fast
02 = Vippefare
03 = Transport i motorkjøretøyer
05 = Klemfare

FR: Avertissement: Ce symbole apparaît dans le guide de l'utilisateur avec un numéro faisant référence aux instructions ci-dessous. Il attire l'attention sur les situations dans lesquelles la sécurité du produit ou de l'utilisateur ou du soignant peut se trouver compromise
01 = Risques de coincement
02 = Risques à la bascule
03 = Transport à bord de véhicules motorisés
05 = Risques de pincement

RU: Предупреждение: Данное обозначение указывается в руководстве по эксплуатации вместе с номером, который относится к нижеприведенным инструкциям. Оно используется для привлечения внимания к ситуациям, в которых существует опасность для изделия, пользователя или лица, осуществляющего уход за пользователем
01 = Риск защемления
02 = Наклонное положение
03 = Передвижение в транспортных средствах
05 = Риск сжатия

JP: 警告: この記号は、以下の説明を示す番号と共にユーザーガイドに表示されています。これは、製品やユーザーまたは介護者が危険にさらされる状況について、注意を喚起します。
01 = 挟まる危険
02 = 傾斜させる際の危険
03 = 自動車内の輸送
05 = 圧迫の危険

DE: Warnung: Dieses Symbol erscheint in der Bedienungsanleitung zusammen mit einer zu den nachfolgenden Anleitungen gehörenden Nummer. Sie lenkt die Aufmerksamkeit auf Situationen, die für das Produkt oder den Betreuer ein Sicherheitsrisiko darstellen können.
01 = Gefahr durch Einklemmen
02 = Kippgefahr
03 = Warnhinweise! - Beförderung in Kraftfahrzeugen
05 = Gefahr durch Quetschen

SV: Varning: Den här symbolen används i handboken tillsammans med ett nummer som hänvisar till instruktionerna nedan. Den uppmärksammar på situationer som kan utgöra en säkerhetsrisk för produkten, användaren eller vårdgivaren.
01 = Risk att fastna
02 = Tipprisk
03 = Transport i fordon
05 = Klämrisk

IT: Avvertenza: Questo simbolo viene utilizzato nel Manuale Utente con un numero di riferimento alle istruzioni riportate di seguito. Richiama l'attenzione alle situazioni in cui la sicurezza del prodotto, dell'utente o dell'operatore potrebbe essere in pericolo
01 = Pericolo di incastro
02 = Pericoli durante la reclinazione della seduta
03 = Trasporto nei veicoli a motore
05 = Pericolo di schiacciamento

PL: Ostrzeżenie: Ten symbol pojawia się w podręczniku obsługi wraz z numerem odnoszącym się do poniższych instrukcji. Zwraca on uwagę na sytuacje, w których bezpieczeństwo produktu, użytkownika lub opiekuna może być zagrożone.
01 = Ryzyko uwięzienia
02 = Zagrożenia przechyty
03 = Transport w pojazdach silnikowych
05 = Ryzyko zmiążdżenia

NL: Waarschuwing: Dit symbool staat in de gebruiksaanwijzing samen met een getal dat naar de hieronder vermelde instructies verwijst. Het vestigt de aandacht op situaties waarin het product, de gebruiker of de veiligheid van derden in gevaar kan zijn.
01 = Gevaar voor beknelling
02 = Kantelgevaar
03 = Vervoer in motorvoertuigen
05 = Gevaar voor samendrukken

FIN: Varoitus: Tämä symboli näkyy käyttöohjeessa yhdessä numeron kanssa, joka viittaa jäljempänä näkyviin ohjeisiin. Sen avulla kiinnitetään huomiota tilanteisiin, joissa tuote tai käyttäjän tai hoitajan turvallisuus voi vaarantua.
01 = Juuttumisvaarat
02 = Vaarat kallistettaessa
03 = Kuljettaminen moottoriajoneuvoissa
05 = Puristumisvaara

PT: Aviso: Este símbolo aparece no Guia do Utilizador juntamente com um número a remeter para as instruções abaixo. Chama a atenção para situações em que possa estar em risco a segurança do produto, do utilizador ou do prestador de cuidados.
01 = Riscos de armadilha
02 = Perigos de basculação
03 = Transporte nos veículos motorizados
05 = Riscos de compressão

CZ: Upozornění: Tento symbol je uveden v uživatelské příručce spolu s číslem odkazujícím na níže uvedené ilustrace. Upozorňuje na situace možného ohrožení bezpečnosti produktu, uživatele nebo pečovatele.
01 = Nebezpečí zachycení
02 = Riziko při naklápění
03 = Přeprava v motorových vozidlech
05 = Nesprávné použití

DK: Advarsel: Dette symbol vises i brugervejledningen sammen med en nummerhenvisning til nedenstående instruktioner. Det henleder opmærksomheden på situationer, hvor produktet, brugeren eller plejerens sikkerhed kan være i fare
01 = Risiko for fastklemning
02 = Fare for tilt af produkt
03 = Transport i motorkøretøjer
05 = Risiko for klemning

ES: Advertencia: Este símbolo aparece en la Guía del usuario junto con un número de referencia a las siguientes instrucciones. Llama la atención sobre situaciones en las que el producto o el usuario o la seguridad del cuidador pueda estar en peligro
01 = Riesgos de atrapamiento
02 = Peligro de vuelco
03 = Transporte en vehículos
05 = Riesgo de aplastamiento
BR: Advertência: Este símbolo aparece no Manual do Usuário, juntamente com um número relacionado às instruções abaixo. Ele serve para indicar situações nas quais a segurança do produto, do usuário ou do cuidador possa estar comprometida
01 = Riscos de armadilha
02 = Perigos da Inclinação
03 = Transporte nos veículos motorizados
05 = Riscos de compressão

SN: 警告: 在用户指南中该符号同数字一起出现, 指示下方所列的各种说明。其目的是唤起对产品、用户或照管者可能处于危险的注意
01 = 卡住危险
02 = 倾斜危险
03 = 汽车运输
05 = 挤压危险

GR: Προειδοποίηση: Αυτό το σύμβολο εμφανίζεται στις οδηγίες χρήσης συνοδευόμενο από έναν αριθμό που αναφέρεται στις παρακάτω οδηγίες. Εμφανίζει την προσοχή σε καταστάσεις στις οποίες ενδέχεται να υφίσταται κίνδυνος για την ασφάλεια του προϊόντος, του χρήστη ή του φροντιστή
01 = Κίνδυνος παγίδευσης
02 = Κίνδυνος ανατροπής
03 = Μεταφορά σε μηχανοκίνητα οχήματα
05 = Κίνδυνος συμπίεσης



EN: Prohibition: Do not stand on the foot support

NO: Forbudt! Ikke bruk fotstøtten som trinn

FR: Interdiction: Ne pas utiliser le repose pieds pour un transfert debout

RU: Запрещено!: Не становитесь на подставку для ног

JP: 禁止：フットサポートの上に立って乗り降りしないでください。

DE: Verbot: Nicht auf der Fußstütze stehen

SV: Förbud: Använd inte fotstödet för stående transport

IT: Attenzione: Non stare in piedi sulla pedana

PL: Zakaz: Nie stawać na płytach podnóżka

GR: Απαγόρευση: Μην χρησιμοποιείτε το πόδι στηρίξης για τους όρθιους μεταφορές

NL: Waarschuwing: Gebruik de voetenplaat niet voor staande transfers

FIN: Kielletty: Älä seisoo jalka tuki

PT: Proibição: Não utilize o apoio de pés em transferências de pé

CZ: Zákaz: Nepoužívejte podpěry nohou pro převozy vestoje

DK: Forbud: Brug ikke fodstøtten som trædeplade

ES: Prohibición: No utilice el reposapies para las transferencias

BR: Proibido: No utilice el soporte de pie para las transferencias de pie

SN: 禁止：不要使用用於傳輪站立腳支撐



EN: Prohibition: Incorrect lifting points, especially on stairs

NO: Forbudt! Ikke dra/løft stolen i kjørehåndtakene, spesielt ikke i trapper

FR: Interdiction: N'utilisez pas la barre de poussée pour tirer/soulever le fauteuil, notamment dans les escaliers

RU: Запрещено!: Не тяните/поднимайте кресло-коляску за ручку, особенно на ступеньках

JP: 禁止：プッシュブレスを持って、シートを引っ張ったり、持上げたりしないでください。（特に階段使用時）

DE: Achtung: Ziehen oder heben Sie den Rollstuhl, insbesondere auf Treppen, nicht mit dem Schiebebügel bzw. den Schiebegriffen

SV: Förbud: Dra/lyft inte stolen genom att hålla i körbygeln, framför allt inte i trappor

IT: Attenzione: Non tirare o sollevare la carrozzina con il maniglione di spinta, soprattutto sulle scale

PL: Zakaz: Nie ciągnąć/podnosić wózka za uchwyty do prowadzenia, w szczególności na schodach

GR: Απαγόρευση: Μην τραβάτε/ανασηκώνετε το αμαξίδιο μέσω της χειρολαβής ώθησης, ειδικά σε σκάλες

NL: Waarschuwing: Onjuiste otilpunten, vooral op de trap.

FIN: Kielletty: Älä vedä/nosta tuolia työntötangosta, etenkään portaissa

PT: Proibição: Não puxe ou levante a cadeira pelo push de impulso, especialmente em escadas

CZ: Zákaz: Netahejte a nezvedejte podvozek za vzpěru, zvláště ne na schodech

DK: Forbud: Forkerte løftepunkter, især ved løft på trapper

ES: Prohibición: No tire hacia arriba ni levante la silla sujetándola del asa de empuje, especialmente en las escaleras

BR: Proibido: Não puxe ou levante a cadeira pela alça de condução, especialmente em escadas

SN: 禁止：不要用推杆拉或提升椅子，尤其在階梯上時。

**EN:** Warewashing machine**NO:** Desinfiseringsmaskin**FR:** Machine à laver**RU:** Посудомоечная машина**JP:** 器具洗浄機**DE:** Spezialwaschmaschine (für Rehaprodukte)**SV:** Rengöring av produkten i maskin**IT:** Lavastoviglie industriale**PL:** Zmywarka**GR:** Πλυντήριο εξοπλισμού**NL:** Vvaatwasser**FIN:** Ei saa pestä pesu-koneessa**PT:** Máquina de lavar loiça**CZ:** Myčka na zdravotní pomůcky**DK:** Industri-vaskemaskine**ES:** Máquina de lavado**BR:** Máquina de lavar loiça**SN:** 请勿使用洗碗机清洗**EN:** Manual cleaning: Keep clean to maintain optimum function**NO:** Manuell rengjøring: Holdes rent for å opprettholde optimal funksjon**FR:** Nettoyage manuel: Nettoyer régulièrement ce produit pour assurer une utilisation optimale**RU:** ручная чистка : Поддерживайте изделие в чистоте для поддержания его оптимального функционирования**JP:** 手動洗浄：機能を最適に維持するために常に清潔にしておいてください**DE:** Manuelle Reinigung: Halten Sie das Produkt sauber um eine optimale Funktionstüchtigkeit zu gewährleisten**SV:** Manuell rengöring: Håll produkten ren för optimal funktion**IT:** Pulizia maniale: Mantenere pulito per mantenere un funzionamento ottimale**PL:** Czyszczenie ręczne: Utrzymywać w czystości, aby zapewnić optymalne funkcjonowanie**GR:** χειροκίνητο καθαρισμό: Διατηρείτε το προϊόν καθαρό για να εξασφαλίσετε την άψογη λειτουργία του**NL:** Handmatige reiniging: Schoonhouden om een optimale werking te behouden**FIN:** Manuaalinen puhdistus: Puhtaanaapito ylläpitää optimaalisen toiminnan**PT:** Limpeza manual: Mantenha o produto limpo para conservar o bom funcionamento**CZ:** Čištění ruční: Udržujte v čistotě a tím zajistíte optimální funkčnost**DK:** Manuel rengøring: Skal holdes rent for at opretholde optimal funktion**ES:** Limpieza manual: Mantenga la limpieza para conservar el funcionamiento óptimo del producto**BR:** Limpeza manual: Mantenha o produto limpo para sempre contar com sua melhor função**SN:** 手工清洗：做好产品清洁，以维持设备的最佳功能。**EN:** Inspection**NO:** Undersøkelse**FR:** Inspection**RU:** осмотр**JP:** 検査**DE:** Inspektion**SV:** Inspektion**IT:** Inspezione**PL:** Kontrola**GR:** Επιθεώρηση**NL:** Inspectie**FIN:** Tarkastus**PT:** Inspeção**CZ:** Inspekce**DK:** Inspektion**ES:** Inspección**BR:** Inspeção**SN:** 检查**EN:** Listen to click sound**NO:** Lytt etter en klikkelyd**FR:** Écoutez le dé clic**RU:** Прислушайтесь, чтобы услышать щелчок**JP:** カチッと音が聞こえます**DE:** Achten Sie auf das Klicken.**SV:** Lyssna efter klickljudet**IT:** Attendere che venga emesso un clic**PL:** Nasłuchuj dźwięku zatrzaśnięcia.**GR:** Ακούστε το κλικ**NL:** Let op het klikgeluid.**FIN:** Kuuntele napsahtavaa ääntä**PT:** Ouvir o som de clique**CZ:** Věnujte pozornost zvuku cvaknutí**DK:** Vær opmærksom på klik lyden**ES:** Escuche el clic**BR:** Ouça ao som de clique**SN:** 注意听叩击声

mm (inch)

	 1	 2	 3	 4
 Overall width	440 (17¼")	460 (18")	500 (19¾")	540 (21¼")
 Length frame	660 (26")	660 (26")	660 (26")	660 (26")
 Folded height, frame	200 (8")	200 (8")	200 (8")	200 (8")
 Folded length, frame	740 (29")	740 (29")	740 (29")	740 (29")
 Seat surface height at front edge	500–600 (19¾–23½)	500–600 (19¾–23½)	500–600 (19¾–23½)	500–600 (19¾–23½)
 Overall height	860 mm (33¾")	890 mm (35")	930 mm (36½")	950 mm (37½")
 Lower leg length	180–260 (7–10¼")	250–350 (9¾–13¾")	300–400 (11¾–15¾")	300–400 (11¾–15¾")
 Leg to seat surface angle	90–60°	90–60°	90–60°	90–60°
 Seat plane angle	-15–35°	-15–35°	-15–35°	-15–35°
 Mass device	11 kg (24.2 lb)	13 kg (28.6 lb)	14 kg (30.8 lb)	15 kg (33 lb)
 Max user mass	35 kg (77.1 lb)	50 kg (110.2 lb)	60 kg (132.2 lb)	70 kg (154.3 lb)
 Max rated load	48 kg (105.8 lb)	65 kg (143.3 lb)	76 kg (167.5)	87 kg (191.8 lb)

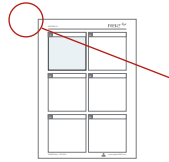
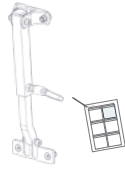

9996097364

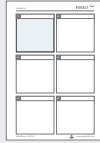
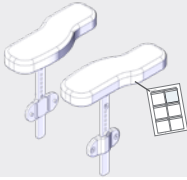

9996097365

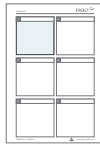

9996097366

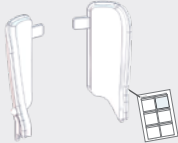

9996097367

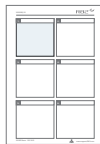
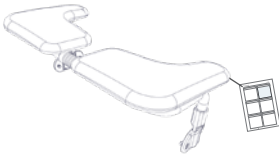

9996097368



9996097369

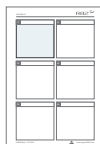
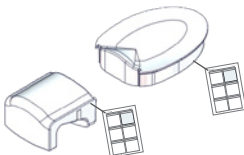

9996097370

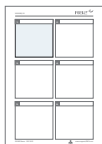
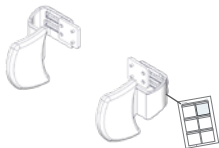

9996097373

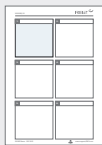
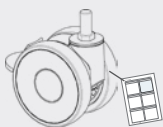

9996097632

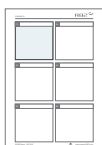

9996097363

ENGLISH

We appreciate your choice of a new product from R82 - a worldwide supplier of technical aids and appliances for children and teenagers with special needs. To fully benefit from the options offered by this product please read this User Guide before use and save it for future reference.

Intended purpose

The Flamingo Bath Frame is a toilet/bathing frame with user friendly angle and height adjustment. The Flamingo Bath Frame is designed for Flamingo seats and can be placed over the toilet or used freestanding with a pan. The product is for indoor use in a bathroom environment.

Enclosed tools:

- 5 mm Allen key



Declaration of Conformity

This product conforms to the requirements of the Medical Devices Regulation (2017/745). The CE mark must be removed when rebuilding the product, when used in combination with a product from another manufacturer or when using other than original R82 spare parts and fittings. Further, this product conforms to the requirements according to:

- EN 12182



Disposal

When a product reaches the end of its lifetime, it should be separated by material type so that the parts can be recycled or disposed of properly. If required, please contact your local dealer for a precise description of each material. Please contact your local authorities to be informed of the options available for recycling in an environmentally-friendly way.

Accessories and spare parts

The products from R82 can be supplied with a variety of accessories which comply with the needs of the individual user. Spare parts can be ordered on request. Find the specific accessories on our website or contact your local dealer for further information.

R82 Warranty

R82 offers a 2-year warranty against defects in workmanship and materials and a 5-year warranty on breakage of the metal frame caused by defects in welds. The warranty would be adversely affected if the customer's responsibility of servicing and/or maintenance is not carried out according to the guidelines and intervals prescribed by the supplier and/or stated in the User Guide. For further information, we refer to the R82 homepage/download.

The warranty is only granted in the country where the product was purchased and if the product can be identified by the serial number. The warranty does not cover accidental damage, including damage caused by misuse or neglect. The warranty does not extend to consumable items e.g. tires or upholstery, which are subject to normal wear and tear and need periodic replacement.

The warranty is null and void if other than original parts/accessories are used, or if the product has not been maintained, repaired or altered according to the guidelines and intervals prescribed by the supplier and/or stated in the User Guide. R82 reserves the right to inspect the product being claimed for and the relevant documentation before agreeing to the warranty claim, and to decide upon whether to replace or repair the defective product. It is the customer's responsibility to return the item being claimed for under warranty to the address of purchase.

Presales information

- support.r82.org

Safety

Signs, symbols and instructions placed on this product must never be covered or removed and must remain present and clearly legible throughout the entire lifetime of the product. Immediately replace or repair illegible or damaged signs, symbols and instructions. Contact your local dealer for instructions.

In case of an adverse event occurred in relation to the device, incidents should be reported to your local dealer and the national competent authority in a timely manner. The local dealer will forward information to manufacturer.

Caregiver

- Read the “User Guide” carefully before use and keep it for future reference. Incorrect use of this product may cause serious injury to the user
- This product contains small parts which could present a choking hazard if removed from their intended placing
- Always use the correct lifting techniques and aids for this purpose
- Never leave the user unattended in this product. Ensure permanent supervision by an adult
- Repair/replacements must only be made using new original R82 spare parts and fittings and carried out in accordance with the guidelines and service intervals prescribed by the supplier
- If there is any doubt as to the continued safe use of your R82 product or if any parts should fail, stop using the product immediately and contact your local dealer as soon as possible
- Ensure that moving parts does not squeeze or trap body parts when adjusting them

Environment

- Observe the surface temperature on the product, before placing an user in it. This goes especially for users with insensitive skin as they cannot feel the heat. If the surface temperature is above 41 °C then allow the product to cool before use
- Use this product on a level surface without any obstacles. Be aware of reduced maneuverability on slippery surfaces
- When using on inclines, please refer to measurements

User

- If the user is close to the max. load limit and/or has a lot of involuntary movements, e.g. rocking, a larger size with a higher max. load or a different R82 product should be considered

Product

- Carry out all positional adjustments on the product and accessories and ensure that all knobs, screws and buckles are securely fastened before use. Keep all tools out of the reach of children
- Activate the brakes before placing the user into the product
- Ensure the stability of the product is maintained before placing the user in it
- We recommend you notify the user before angling the seat and back
- Ensure the wheels are fully-functional and secure before use
- Inspect the product and all of its accessories and replace any worn out parts before use

Service information

Maintenance of a medical device is wholly the responsibility of the owner of that device. Failure to maintain a device in accordance with the instructions may invalidate the device's warranty. Furthermore, failure to maintain a device may compromise the clinical condition or safety of users and/or their caregivers. Do not perform service and maintenance while the user is in the product.

1st Day

- Read the User Guide carefully before use and store it in a safe place for future reference
- Store the enclosed tools on/at the product

After every use

- Wipe the product dry

Daily

- Use a dry cloth to clean the product
- Visual inspection. Repair or replace any damaged or worn-out parts
- Ensure that all fasteners are in place and fitted correctly
- Check all fittings and buckles for signs of worn out parts
- Be aware of any MAX mark indications before adjustment

Weekly

- Check that all castors are moving freely and that all wheel locks/brakes are easily activated
- Wipe off any residue and dirt from the product using a cloth with warm water and a mild detergent/soap and dry before use

Monthly

- Nuts and bolts on the product are tightened
- Oil the swing-away parts

Annually

- Inspect the frame for cracks or signs for worn-out parts and carry out annual service. Never use a product which appears to be substandard or faulty

Disinfection

The product without accessories can be disinfected with a 70% disinfectant IPA solution. It is recommended to wipe off any residue and dirt from the product, using a cloth with warm water and a mild detergent/soap without chlorine and let it dry before disinfection.

Warewashing machine

This product can be washed at 60° using a mild detergent for 10 minutes in a washing machine designed for medical devices. Use the machine's drying function to dry the product.

This product can be washed at 85° using a mild detergent for 3 minutes in a washing machine designed for medical devices. Use the machine's drying function to dry the product.

Remove the following items and clean them separately: Cushioning and Seat

Service interval

A detailed inspection of the product must be made every 12 months (every 6 months for heavy users) and every time the product is reissued for use. The inspection should be carried out by a technically competent person who has been trained in the use of the product.

The lifetime of this product in normal use is 5 years if all maintenance and servicing is carried out in accordance with the manufacturer's instructions and demonstrably recorded.

Service Check List:

Check and adjust the following functions as per their intended use. Repair or replace any damaged or worn-out parts. Please check the:

- Product can be folded for storage or transportation
- Frame is adjustable in height
- Seat plane is adjustable and can be locked in position
- Adjustment options for the foot rest, it is possible to lock the angle and fasten the telescopic tubes in position
- Nuts and bolts on the product are tightened
- Oil the swing-away parts