

Transport Chairs

Invacare Transport

Lightweight Transport

Bariatric Transport

Lite Transport

DEALER: This manual **MUST** be given to the user of this product.

USER: **BEFORE** using this product, read this manual and save for future reference.

For more information regarding
Invacare products, parts, and services,
please visit www.invacare.com



Yes, you can.®

⚠ WARNING

DO NOT OPERATE THIS EQUIPMENT WITHOUT FIRST READING AND UNDERSTANDING THIS MANUAL. IF YOU ARE UNABLE TO UNDERSTAND THE WARNINGS, CAUTIONS, AND INSTRUCTIONS, CONTACT A HEALTHCARE PROFESSIONAL, DEALER OR A QUALIFIED TECHNICIAN BEFORE ATTEMPTING TO USE THIS EQUIPMENT - OTHERWISE INJURY OR DAMAGE MAY RESULT.

PROCEDURES OTHER THAN THOSE DESCRIBED IN THIS MANUAL MUST BE PERFORMED BY A QUALIFIED TECHNICIAN.

NOTE: Updated versions of this manual are available on www.invacare.com.

TABLE OF CONTENTS

REGISTER YOUR PRODUCT	4
SPECIAL NOTES	5
LABEL LOCATIONS	6
Invacare Transport, Lightweight Transport, and Lite Transport.....	6
Bariatric Transport.....	7
TYPICAL PRODUCT PARAMETERS	8
SECTION 1—GENERAL GUIDELINES	10
Operating Information.....	10
Weight Training	11
Weight Limitation.....	11
SECTION 2—SAFETY/HANDLING	12
Safety/Handling of Transport Chairs.....	12
Stability and Balance	12
Coping with Everyday Obstacles.....	13
A Note to Transport Chair Assistants	13
Reaching, Leaning and Bending Forward	13
Reaching, Leaning Backwards	14
Tipping.....	14
Stairways	15
Folding and Unfolding Transport Chair	16
Unfolding	16
Folding	17
SECTION 3—SAFETY INSPECTION	18
Safety Inspection Checklists.....	18
Inspect/Adjust Initially	18
Inspect/Adjust Weekly.....	19
Inspect/Adjust Monthly.....	19
Inspect/Adjust Periodically.....	19
Troubleshooting	20
Maintenance	20
Maintenance Safety Precautions	20
Suggested Maintenance Procedures	20
SECTION 4—FRONT RIGGINGS	22
Installing Swingaway Footrest Assembly	22
Adjusting Footplate Height.....	22
SECTION 5—BACK	24

TABLE OF CONTENTS

Unfolding/Folding the Fold-Down Back.....	24
Folding	24
Unfolding.....	24
Replacing Back Upholstery.....	25
Replacing Seat Upholstery.....	25
SECTION 6—REAR WHEELS	26
Removing/Installing Rear Wheels	26
SECTION 7—CASTERS	27
Replacing/Adjusting Front Forks	27
Replacing	27
Adjusting	27
Replacing Front Casters.....	28
SECTION 8—HAND BRAKES/WHEEL LOCKS	29
Locking/Unlocking/Using Hand Brakes.....	29
Locking Hand Brake	29
Unlocking Hand Brake	29
Using Hand Brake	30
Adjusting Hand Brakes	30
Adjusting Brake Handle	30
Adjusting Cable Adjuster Unit.....	31
Adjusting Wheel Lock.....	31
LIMITED WARRANTY	35

REGISTER YOUR PRODUCT

The benefits of registering include:

1. Safeguarding your investment.
2. Ensuring long-term maintenance and servicing of your product.
3. Receiving updates with product information, maintenance tips and industry news.

Register ONLINE at warranty.invacare.com

Please have your model number and purchase date available to complete your registration.

Any registration information you submit will only be used by Invacare Corporation and protected as required by applicable laws and regulations.

SPECIAL NOTES

Signal words are used in this manual and apply to hazards or unsafe practices which could result in personal injury or property damage. Refer to the following table for definitions of the signal words.

SIGNAL WORD	MEANING
DANGER	Danger indicates an imminently hazardous situation which, if not avoided, will result in death or serious injury.
WARNING	Warning indicates a potentially hazardous situation which, if not avoided, could result in death or serious injury.
CAUTION	Caution indicates a potentially hazardous situation which, if not avoided, may result in property damage.

NOTICE

THE INFORMATION CONTAINED IN THIS DOCUMENT IS SUBJECT TO CHANGE WITHOUT NOTICE.

TRANSPORT CHAIR USER

As a manufacturer of transport chairs, Invacare endeavors to supply a wide variety of transport chairs to meet many needs of the end user. However, final selection of the type of transport chair to be used by an individual rests solely with the user and his/her healthcare professional capable of making such a selection.

TRANSPORT CHAIR TIE-DOWN RESTRAINTS AND SEAT POSITIONING STRAP

Transport chair users should not be transported in vehicles of any kind while in transport chairs. As of this date, the Department of Transportation has not approved any tie-down systems for transportation of a user while in a transport chair, in a moving vehicle of any type.

It is Invacare's position that users of transport chairs should be transferred into appropriate seating in vehicles for transportation and use be made of the seat positioning strap made available by the auto industry. Invacare cannot and does not recommend any chair transportation systems.

WARNING

Invacare products are specifically designed and manufactured for use in conjunction with Invacare accessories. Accessories designed by other manufacturers have not been tested by Invacare and are not recommended for use with Invacare products.

LABEL LOCATIONS

Invacare Transport, Lightweight Transport, and Lite Transport

NOTE: The Lightweight transport is shown as an example. Unless indicated on this page, label locations and wording are the same for the Invacare transport and the Lite transport.

NOTE: This label is only on the Lite transport.

WARNING BRAKES MUST BE LOCKED BEFORE USING SEAT 1076214	MISE EN GARDE BLOQUER LES FREINS AVANT D'UTILISER LE SIEGE
--	--

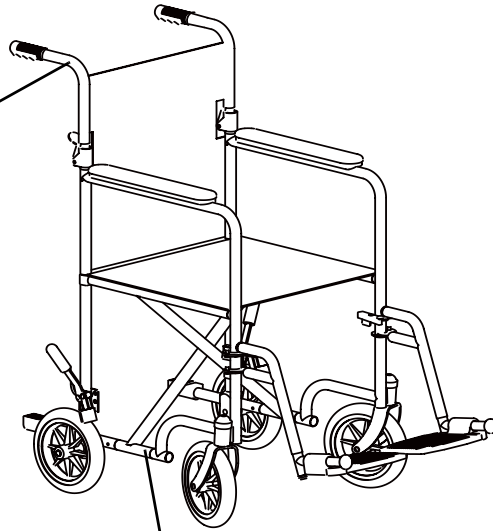

WEIGHT CAPACITY
250 LBS. (114 kgs.)
REFER TO OWNER'S MANUAL
PIN 1143180

View From Back of Chair

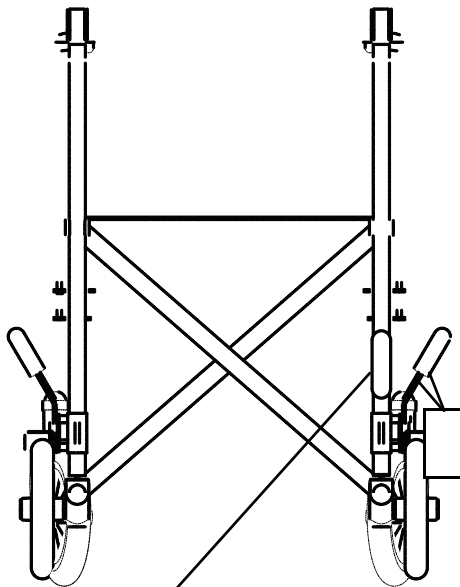

IMPORTANT NOTICE

The wheel locks on this transport chair have been pre-set at the factory to comply with the Veterans Administration functional Standard 8320.01 of the Federal Register, paragraph 3.2.4.5.3. If these wheel locks do not meet your needs, follow instructions below.

CAUTION

Any wheel lock adjustments should embed wheel lock shoe at least 1/8" into tire when locked (3/16" on pneumatic tires).

INSTRUCTIONS FOR WHEEL LOCK ADJUSTMENTS

1. Loosen wheel lock mounting fastener, which runs through mounting bracket and frame.
2. Slide clamp toward rear wheel until wheel lock shoe is embedded into tire material at least 1/8" when handle is engaged to the lock position (3/16" for pneumatic tires).
3. Tighten mounting fastener to secure mounting bracket in desired location and recheck lock shoe embedding.
4. Inspect for correct locking action BEFORE actual use.

PIN 1143193 REV A

NO TRANSPORT CHAIR HAS BEEN APPROVED FOR USE AS A SEATING SURFACE WITHIN A MOTOR VEHICLE. THIS LABEL IS FOR INFORMATIONAL PURPOSES ONLY. LIABILITY ISSUES WERE NOT CONSIDERED IN THE ATTACHMENT OF THIS LABEL.

AUCUNE CHAISE ROULANTE N'A ETE APPROUVEE POUR UTILISATION COMME SIEGE DANS UN VEHICULE MOTORISE. CETTE ETIQUETTE EST POUR INFORMATION UNIQUEMENT. LES QUESTIONS DE RESPONSABILITE N'ONT PAS ETE PRISES EN LIGNE DE COMPTE DANS LE CADRE DE L'APPLICATION DE CETTE ETIQUETTE.

1143180 Rev A - 4/26/06

Bariatric Transport

WARNING
 DO NOT leave the Bariatric Transport on inclined surfaces. The wheel locks and hand brakes may not hold the Bariatric Transport on inclined surfaces due to the transport chair's increased weight capacity.
1130284 Rev B - 4/24/06

WARNING	MISE EN GARDE
BRAKES MUST BE LOCKED BEFORE USING SEAT <small>1076214</small>	BLOQUER LES FREINS AVANT D'UTILISER LE SIEGE

WEIGHT CAPACITY
400 LBS. (182 kgs.)
 REFER TO OWNER'S MANUAL
P/N 1111019

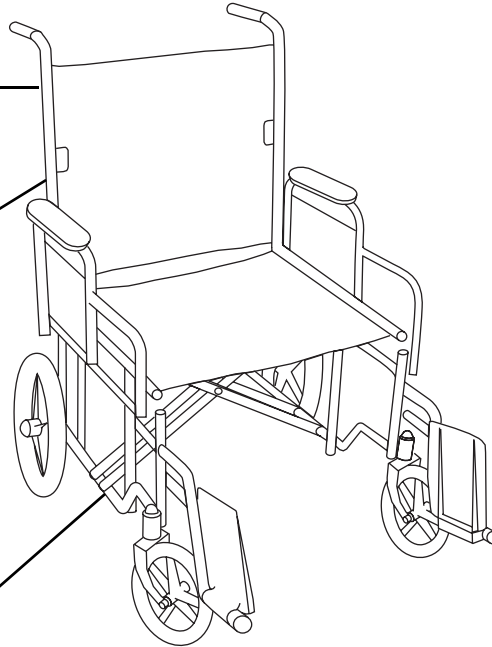

View From Back of Chair

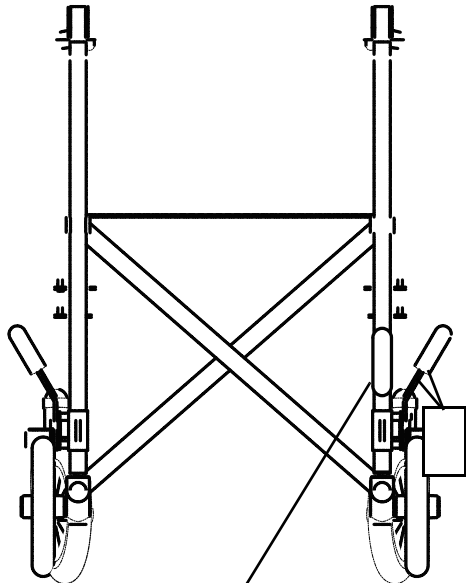

IMPORTANT NOTICE

The wheel locks on this transport chair have been pre-set at the factory to comply with the Veterans Administration functional Standard 8320.01 of the Federal Register, paragraph 3.2.4.5.3. If these wheel locks do not meet your needs, follow instructions below.

CAUTION

Any wheel lock adjustments should embed wheel lock shoe at least 1/8" into tire when locked (3/16" on pneumatic tires).

INSTRUCTIONS FOR WHEEL LOCK ADJUSTMENTS

1. Loosen wheel lock mounting fastener, which runs through mounting bracket and frame.
2. Slide clamp toward rear wheel until wheel lock shoe is embedded into tire material at least 1/8" when handle is engaged to the lock position (3/16" for pneumatic tires).
3. Tighten mounting fastener to secure mounting bracket in desired location and recheck lock shoe embedding.
4. Inspect for correct locking action BEFORE actual use.

P/N 1143193 REV A

NO TRANSPORT CHAIR HAS BEEN APPROVED FOR USE AS A SEATING SURFACE WITHIN A MOTOR VEHICLE. THIS LABEL IS FOR INFORMATIONAL PURPOSES ONLY. LIABILITY ISSUES WERE NOT CONSIDERED IN THE ATTACHMENT OF THIS LABEL.

AUCUNE CHAISE ROULANTE N'A ETE APPROUVEE POUR UTILISATION COMME SIEGE DANS UN VEHICULE MOTORISE. CETTE ETIQUETTE EST POUR INFORMATION UNIQUEMENT. LES QUESTIONS DE RESPONSABILITE N'ONT PAS ETE PRISES EN LIGNE DE COMPTE DANS LE CADRE DE L'APPLICATION DE CETTE ETIQUETTE.
1143180 Rev A - 4/26/06

TYPICAL PRODUCT PARAMETERS

INVACARE TRANSPORT	
SEAT WIDTH (BETWEEN ARMS)	17,18,19 and 20 inches
SEAT DEPTH	16 inches
OVERALL WIDTH	17½ to 22½ inches
OVERALL DEPTH (WITHOUT RIGGINGS)	23 inches
SEAT-TO-FLOOR	19½ inches
BACK STYLE	Fold-down
BACK HEIGHT	18 inches
ARM STYLES	Permanent
FRONT RIGGINGS	Swingaway footrest
REAR AXLE	Permanent
REAR WHEELS	8 X 1 inch
WHEEL LOCKS	Push to lock
CASTER SIZE	8 X 1 inch (Standard)
UPHOLSTERY	Black Nylon
WEIGHT (APPROXIMATE)	26 lbs (without front riggings)
SHIPPING WEIGHT (APPROXIMATE)	30 lbs (without front riggings)
WEIGHT LIMITATION	250 lbs

LIGHTWEIGHT TRANSPORT	
SEAT WIDTH (BETWEEN ARMS)	19 inches and 17 inches
SEAT DEPTH	15¼ inches
OVERALL WIDTH	23½ inches
OVERALL DEPTH (WITHOUT RIGGINGS)	23½ inches and 21½ inches
SEAT-TO-FLOOR	19¼ inches
BACK STYLE	Fold-down
BACK HEIGHT	17½ inches
ARM STYLES	Permanent
FRONT RIGGINGS	Swingaway footrest
REAR AXLE	Permanent
REAR WHEELS	8 X 1 inch
WHEEL LOCKS	Push to lock
CASTER SIZE	8 X 1 inch (Standard)
UPHOLSTERY	Black Nylon
WEIGHT (APPROXIMATE)	19 lbs (without front riggings)
SHIPPING WEIGHT (APPROXIMATE)	26 lbs (without front riggings)
WEIGHT LIMITATION	250 lbs

BARIATRIC TRANSPORT	
SEAT WIDTH (BETWEEN ARMS)	22 inches
SEAT DEPTH	18 inches
OVERALL WIDTH	28 inches
OVERALL DEPTH (WITHOUT RIGGINGS)	28½ inches
SEAT-TO-FLOOR	19½ inches
BACK STYLE	Fold-down
BACK HEIGHT	18 inches
ARM STYLES	Removable
FRONT RIGGINGS	Swingaway footrest
REAR AXLE	Permanent
REAR WHEELS	12½ X 2¼ inch
WHEEL LOCKS	Push to lock
HAND BRAKES	Push down to lock, pull up to stop
CASTER SIZE	8 X 1 inch (Standard)
UPHOLSTERY	Black Nylon
WEIGHT (APPROXIMATE)	41 lbs (without front riggings)
SHIPPING WEIGHT (APPROXIMATE)	45 lbs (without front riggings)
WEIGHT LIMITATION	400 lbs

LITE TRANSPORT	
SEAT WIDTH (BETWEEN ARMS)	19 inches
SEAT DEPTH	18 inches
OVERALL WIDTH	23½ inches
OVERALL DEPTH (WITHOUT RIGGINGS)	24½ inches
SEAT-TO-FLOOR	19¼ inches
BACK STYLE	Fold-down
BACK HEIGHT	17½ inches
ARM STYLES	Permanent
FRONT RIGGINGS	Swingaway footrest
REAR AXLE	Permanent
REAR WHEELS	12 X 1¾ inch
WHEEL LOCKS	Push to lock
HAND BRAKES	Push down to lock, pull up to stop
CASTER SIZE	8 X 1 inch (Standard)
UPHOLSTERY	Black Nylon
WEIGHT (APPROXIMATE)	19 lbs (without front riggings)
SHIPPING WEIGHT (APPROXIMATE)	26 lbs (without front riggings)
WEIGHT LIMITATION	250 lbs

SECTION I—GENERAL GUIDELINES

⚠ WARNING

SECTION I - GENERAL GUIDELINES contains important information for the safe operation and use of this product. **DO NOT** use this product or any available optional equipment without first completely reading and understanding these instructions and any additional instructional material such as **Owner's Manuals, Service Manuals or Instruction Sheets** supplied with this product or optional equipment. If you are unable to understand the **Warnings, Cautions or Instructions**, contact a healthcare professional, dealer or technical personnel before attempting to use this equipment - otherwise, injury or damage may occur.

Operating Information

To determine and establish your particular safety limits, practice bending, reaching and transferring activities in several combinations in the presence of a qualified health professional before attempting active use of the transport chair.

Make sure the back is locked securely before using this transport chair.

ALWAYS check hand grips for looseness before using the transport chair. If loose and/or worn, replace immediately.

If transport chair is exposed to extreme temperature (above 100°F or below 32°F), high humidity and/or becomes wet, prior to use, ensure handgrips **DO NOT** twist on the transport chair handle - otherwise damage or injury may occur.

DO NOT attempt to reach objects if you have to move forward in the seat.

DO NOT attempt to reach objects if you have to pick them up from the floor by reaching down between your knees.

DO NOT lean over the top of the back upholstery to reach objects behind you, as this may cause the transport chair to tip over.

DO NOT shift your weight or sitting position toward the direction you are reaching as the transport chair may tip over.

DO NOT tilt the transport chair without assistance.

DO NOT use an escalator to move a transport chair between floors. Serious bodily injury may occur.

NEVER leave an unoccupied transport chair on an incline.

DO NOT attempt to stop a moving transport chair with wheel locks. Wheel locks are not brakes.

Invacare recommends that a non-folding device be installed to keep the transport chair from being folded when left unoccupied in a public place.

Before attempting to transfer in or out of the transport chair, every precaution should be taken to reduce the gap distance. Turn both casters parallel to the object you are transferring onto. When transferring to and from the transport chair, ALWAYS engage both wheel locks. If the transport chair is equipped with hand brakes, ALWAYS lock both hand brakes before transferring to and from the transport chair.

DO NOT sit or transfer into the transport chair unless it is fully open.

DO NOT operate on roads, streets or highways.

DO NOT climb, go up or down ramps or traverse slopes greater than 9 degrees.

DO NOT attempt to move up or down an incline with a water, ice or oil film.

DO NOT attempt to ride over curbs or obstacles. Doing so may cause your transport chair to tip over and cause bodily harm or damage to the transport chair.

Invacare products are specifically designed and manufactured for use in conjunction with Invacare accessories. Accessories designed by other manufacturers have not been tested by Invacare and are not recommended for use with Invacare products.

DO NOT overtighten hardware attaching to the frame. This could cause damage to the frame tubing.

ALWAYS keep hands and fingers clear of moving parts to avoid injury.

DO NOT stand on the footplates. When getting in or out of the transport chair, make sure that the footplates are in the upward position or swing the footrest towards the outside of the transport chair.

DO NOT attempt to lift the transport chair by any removable (detachable) parts. Lifting by means of any removable (detachable) parts of a transport chair may result in injury to the user or damage to the transport chair.

DO NOT stand on the frame of the transport chair.

Weight Training

Invacare does not recommend the use of its transport chairs as a weight training apparatus. Invacare transport chairs have not been designed or tested as a seat for any kind of weight training. If occupant uses said transport chair as a weight training apparatus, Invacare shall not be liable for bodily injury and the warranty will be void.

Weight Limitation

The following are the weight limitations for the Invacare transport chairs:

TRANSPORT CHAIR	WEIGHT LIMITATION (LBS)
Transport	250
Lightweight Transport	250
Bariatric Transport	400
Lite Transport	250

SECTION 2—SAFETY/HANDLING

Safety/Handling of Transport Chairs

Safety and handling of the transport chair requires the close attention of the transport chair user as well as the assistant. This manual points out the most common procedures and techniques involved in the safe operation and maintenance of the transport chair. It is important to practice and master these safe techniques until you are comfortable in maneuvering around the frequently encountered architectural barriers.

Use this information only as a basic guide. The techniques that are discussed on the following pages have been used successfully by many.

Individual transport chair users often develop skills to deal with daily living activities that may differ from those described in this manual. Invacare recognizes and encourages each individual to try what works best for him/her in overcoming architectural obstacles that they may encounter. However, all warnings and cautions given in this manual **MUST** be followed. Techniques in this manual are a starting point for the new transport chair user and assistant with safety as the most important consideration for all.

Stability and Balance

NOTE: For this procedure, refer to FIGURE 2.1 on page 13.

To assure stability and proper operation of your transport chair, you must at all times maintain proper balance. Your transport chair has been designed to remain upright and stable during normal daily activities as long as you do not move beyond the center of gravity.

Virtually all activities which involve movement in the transport chair have an effect on the center of gravity. Invacare recommends using seat/chest positioning straps for additional safety while involved in activities that shift your weight.

DO NOT lean forward out of the transport chair any further than the length of the armrests. Make sure the casters are pointing in the forward position whenever you lean forward. This can be achieved by advancing the transport chair and then reversing it in a straight line.

⚠ WARNING

DO NOT attempt to reach objects if you have to move forward in the seat or pick them up from the floor by reaching down between your knees.

Many activities require the transport chair owner to reach, bend and transfer in and out of the transport chair. These movements will cause a change to the normal balance, the center of gravity, and the weight distribution of the transport chair. To determine and establish your particular safety limits, practice bending, reaching and transferring activities in several combinations in the presence of a qualified healthcare professional before attempting active use of the transport chair.

Proper positioning is essential for your safety. When reaching, leaning, or bending forward, it is important to use the front casters as a tool to maintain stability and balance.

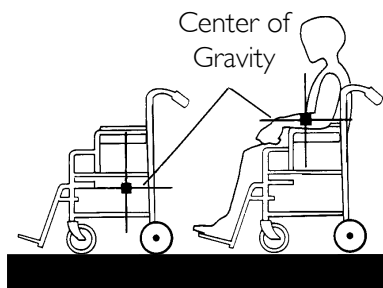

FIGURE 2.1 Stability and Balance

Coping with Everyday Obstacles

Coping with the irritation of everyday obstacles can be alleviated somewhat by learning how to manage your transport chair. Keep in mind your center of gravity to maintain stability and balance.

A Note to Transport Chair Assistants

When assistance to the transport chair user is required, remember to use good body mechanics. Keep your back straight and bend your knees whenever tipping the transport chair or traversing curbs, or other impediments.

⚠ WARNING

DO NOT attempt to lift the transport chair by any removable (detachable) parts. Lifting by means of any removable (detachable) parts of a transport chair may result in injury to the user or damage to the transport chair.

Always verify that hand grips on the rear cane are secure prior to use when an assistant is used to propel or lift the chair. Check for any signs of looseness or deterioration and if found, contact a qualified technician. DO NOT attempt to move the transport chair by pulling on the hand grips if they are found to be unsecure or have deteriorated.

Also, be aware of detachable parts such as armrests or legrests. These must NEVER be used to move the transport chair or as lifting supports, as they may be inadvertently released, resulting in possible injury to the user and/or assistant(s).

When learning a new assistance technique, have an experienced assistant help you before attempting it alone.

Reaching, Leaning and Bending Forward

NOTE: For this procedure, refer to FIGURE 2.2 on page 14.

Position the front casters so that they are extended as far forward as possible and lock the hand brakes.

⚠ WARNING

DO NOT attempt to reach objects if you have to move forward in the seat or pick them up from the floor by reaching down between your knees.

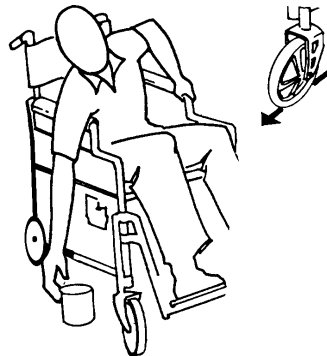

FIGURE 2.2 Reaching, Leaning and Bending Forward

Reaching, Leaning Backwards

⚠ WARNING

DO NOT lean over the top of the back upholstery. This will change your center of gravity and may cause you to tip over.

NOTE: For this procedure, refer to FIGURE 2.3.

Position transport chair as close as possible to the desired object. Point front casters forward to create the longest possible wheelbase. Reach back only as far as your arm will extend without changing your sitting position.



FIGURE 2.3 Reaching, Leaning Backwards

Tipping

⚠ WARNING

DO NOT tip the transport chair without assistance.

NOTE: For this procedure, refer to FIGURE 2.4 on page 15.

When tipping the transport chair, an assistant should grasp the back of the transport chair on a non-removable (non-detachable) part. Inform the transport chair occupant before tipping the transport chair and remind him/her to lean back. Be sure the occupant's feet and hands are clear of all wheels and/or pinch points.

After mastering the techniques of tipping the transport chair, use the following method to tackle curbs, short stairs, etc.

Place a foot on the step tube and begin to tilt the transport chair toward you. Apply a continuous downward motion until the balance point is achieved and the front casters clear the curb. At this point, the assistant will feel a difference in the weight distribution.

⚠ WARNING

When lowering the front casters of the transport chair, DO NOT let the transport chair drop the last few inches to the ground. This could result in injury to the occupant and/or damage to the transport chair.

Roll the transport chair forward and slowly lower the front of the transport chair in one continuous movement onto the sidewalk. Push the transport chair forward until the rear wheels roll up and over the curb.

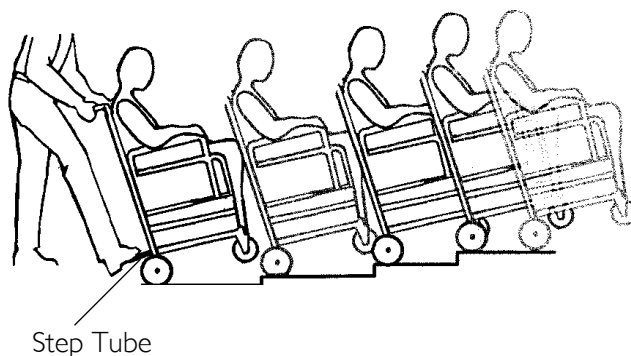

FIGURE 2.4 Tipping

Stairways

⚠ WARNING

DO NOT attempt to lift a transport chair by lifting on any removable (detachable) parts. Lifting by means of any removable (detachable) parts of a transport chair may result in injury to the user or damage to the transport chair.

Always verify that hand grips on the rear cane are secure prior to use when an assistant is used to propel or lift the chair. Check for any signs of looseness or deterioration and if found, contact a qualified technician. DO NOT attempt to move the transport chair by pulling on the hand grips if they are found to be unsecure or have deteriorated.

Extreme caution is advised when it is necessary to move an occupied transport chair up or down the stairs. Invacare recommends that, if possible, the user be removed from the transport chair prior to moving. Invacare recommends using two assistants and making thorough preparations. Make sure to use only secure, non-detachable parts for hand-held supports.

Follow this procedure for moving the transport chair between floors when an elevator is NOT available:

1. After the transport chair has been tilted back to the balance point, one assistant (in the rear) backs the transport chair up against the first step, while securely grasping a non-removable (non-detachable) part of the transport chair for leverage.
2. The second assistant, with a firm hold on a non-detachable part of the framework, lifts the transport chair up and over the stair and steadies the transport chair as the first assistant places one foot on the next stair and repeats STEP 1.
3. The transport chair should not be lowered until the last stair has been negotiated and the transport chair has been rolled away from the stairway.

⚠ WARNING

DO NOT use an escalator to move a transport chair between floors. Serious bodily injury may occur.

Folding and Unfolding Transport Chair

Unfolding

NOTE: For this procedure, refer to FIGURE 2.5.

1. Open the transport chair by grasping the push handle of the transport chair closest to you.
2. Tilt the transport chair toward you (raising the opposite wheel and caster off the ground/floor).
3. Push downward on the top of the seat rail closest to you where the seat upholstery is attached until the transport chair is fully open.

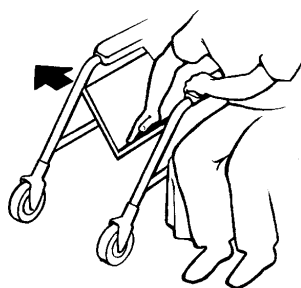

FIGURE 2.5 Unfolding

Folding

⚠ WARNING

ALWAYS use the straps on the seat rails when folding the transport chair. Otherwise, hands and fingers may become pinched between the seat rail and the armrest and injury may occur.

NOTE: For this procedure, refer to FIGURE 2.6.

1. Swing the footrest/legrest in locked position to the front of the transport chair.
2. Pivot the footplates upward to vertical position.
3. Grasp the two straps on the seat rails and pull up to begin closing the transport chair.
4. Continue to close the transport chair by grasping the armrest furthest from you and pulling the armrest toward you.

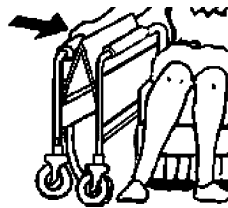

FIGURE 2.6 Folding

SECTION 3—SAFETY INSPECTION

NOTE: Every six months take your transport chair to a qualified technician for a thorough inspection and servicing. Regular cleaning will reveal loose or worn parts and enhance the smooth operation of your transport chair. To operate properly and safely, your transport chair must be cared for just like any other vehicle. Routine maintenance will extend the life and efficiency of your transport chair.

Safety Inspection Checklists

Initial adjustments should be made to suit your personal body structure and preference. Thereafter follow these maintenance procedures:

Inspect/Adjust Initially

- Ensure transport chair rolls straight (no excessive drag or pull to one side).
- Inspect seat and back upholstery for rips or sagging.
- Inspect back cane hand grips for wear, looseness, and/or deterioration.
- Inspect for any loose or broken hardware on the transport chair.
- Ensure that there is no excessive side movement or binding when the rear wheels are lifted and spun.
- Inspect for cracked, broken or loose spokes.
- Ensure the wheel/fork assembly has proper tension when the caster is spun. The caster should come to a gradual stop.
- Loosen/tighten the locknut if the wheel wobbles noticeably or binds to a stop.
- Ensure the wheel bearings are clean and free of moisture.

CAUTION

As with any vehicle, wheels and tires should be checked periodically for cracks and wear and should be replaced as necessary.

- Inspect the tires for flat spots and wear.
- Ensure the hand brakes DO NOT interfere with the tires when rolling.
- Ensure the hand brake pivot points are free of wear and looseness.
- Ensure the hand brakes are easy to engage.
- Clean upholstery and armrests.

Inspect/Adjust Weekly

- Ensure the transport chair rolls straight (no excessive drag or pull to one side).
- Inspect for cracked, broken or loose spokes.
- Ensure the wheel/fork assembly has proper tension when caster is spun. The caster should come to a gradual stop.
- Ensure the hand brakes do not interfere with tires when rolling.
- Ensure the hand brake pivot points are free of wear and looseness.

Inspect/Adjust Monthly

- Inspect for any loose or broken hardware on the transport chair.
- Inspect back cane hand grips for wear, looseness, and/or deterioration.
- Loosen/tighten the locknut if the wheel wobbles noticeably or binds to a stop.
- Ensure the wheel bearings are clean and free of moisture.

CAUTION

As with any vehicle, the wheels and tires should be checked periodically for cracks and wear and should be replaced as necessary.

- Ensure the hand brakes do not interfere with the tires when rolling.

Inspect/Adjust Periodically

- Ensure the transport chair rolls straight (no excessive drag or pull to one side).
- Inspect the seat and the back upholstery for rips or sagging.
- Ensure that there is no excessive side movement or binding when the rear wheels are lifted and spun.
- Ensure the wheel bearings are clean and free of moisture.

CAUTION

As with any vehicle, the wheels and tires should be checked periodically for cracks and wear and should be replaced as necessary.

- Ensure that casters are free of debris.
- Inspect the tires for flat spots and wear.
- Ensure the hand brakes are easy to engage.
- Clean the upholstery and armrests.
- Check that all labels are present and legible. Replace if necessary.

Troubleshooting

Chair Veers Left/Right	Sluggish Turn or Performance	Casters Flutter	Squeaks and Rattles	Looseness in Chair	Chair 3 Wheels	Solutions
X	X	X	X	X		Check for loose fork stem nuts and bolts.
X		X				Check that both casters contact the ground at the same time.

Maintenance

Maintenance Safety Precautions

⚠ WARNING

After **ANY** adjustments, repair or service and **BEFORE** use, make sure all attaching hardware is tightened securely. Otherwise, injury or damage can result.

CAUTION

DO NOT overtighten the hardware attaching to the frame. This could cause damage to the frame tubing.

Suggested Maintenance Procedures

1. Before using your transport chair, do the following:
 - A. Make sure all the nuts and bolts are tight.
 - B. Check all the parts for damage or wear and replace.
 - C. Check all parts for proper adjustment.
2. Periodically check the wheels and tires for cracks and wear. Have a qualified technician replace if damaged.
3. Periodically adjust the wheel locks in correlation to tire wear. Refer to Adjusting Wheel Lock on page 31.
4. Periodically check the front caster and the rear wheel hubs to make sure they are clean and free of cracks.

⚠ WARNING

When cleaning the rear cane or hand grip areas, use only a clean towel lightly dampened with cool water. Verify that grips are dry prior to use. The use of soap or ammonia based cleaning solutions will result in the hand grips sliding off the cane assembly. Failure to observe this warning could result in injury to the user or bystanders.

5. Hand grips should be checked monthly for wear/looseness. Clean if desired.
6. Check the upholstery for sagging, rips or tears.

SECTION 4—FRONT RIGGINGS

⚠ WARNING

After any adjustments, repair or service and before use, make sure all attaching hardware is tightened securely. Otherwise, injury or damage may result.

Installing Swingaway Footrest Assembly

NOTE: For this procedure, refer to FIGURE 4.1.

1. Turn the footrest to the side (open footplate is perpendicular to transport chair).
2. Install the hinge plates on the footrest onto the hinge pins on the transport chair frame.
3. Push the footrest towards the inside of the transport chair until it locks into place.

NOTE: The footplate will be on the inside of the transport chair when locked in place.

4. Repeat this procedure for the other footrest assembly.
5. To release the footrest, push the footrest release lever inward, rotate the footrest outward.

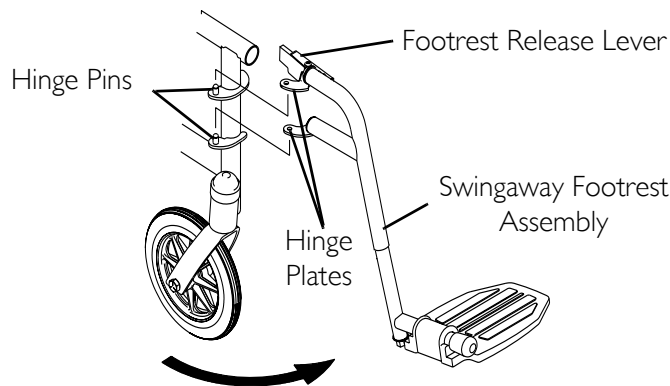

FIGURE 4.1 Installing Swingaway Footrest Assembly

Adjusting Footplate Height

NOTE: For this procedure, refer to FIGURE 4.2 on page 23.

1. Remove the swingaway footrest assembly. Refer to [Installing Swingaway Footrest Assembly](#) on page 22.

NOTE: Lay the assembly on a flat surface to simplify this procedure.

2. Loosen, but DO NOT remove, the footplate mounting bolt until the footplate assembly moves freely.
3. Reposition the footplate assembly to the desired height.
4. Securely tighten the footplate mounting bolt.

5. Repeat this procedure for the other footrest, if necessary.
6. Reinstall the swingaway footrest assembly. Refer to Installing Swingaway Footrest Assembly on page 22.

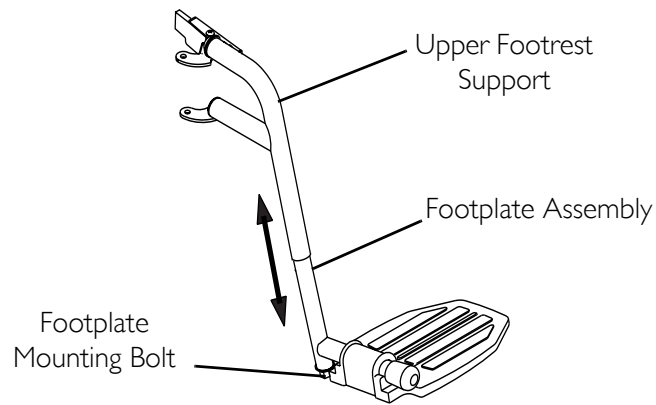

FIGURE 4.2 Adjusting Footplate Height

SECTION 5—BACK

⚠ WARNING

After any adjustments, repair or service and before use, make sure all attaching hardware is tightened securely. Otherwise, injury or damage could result.

Unfolding/Folding the Fold-Down Back

NOTE: For this procedure, refer to FIGURE 5.1.

Folding

1. Disengage the release mechanism on the back canes.
2. Pull the handles down.

Unfolding

⚠ WARNING

When unfolding the back, ensure all occupant's and/or assistant's body parts are away from the folding mechanism. Otherwise, pinching and injury may occur.

Make sure the release levers are securely locked in place before using the transport chair.

1. Pull up on the two back canes until the release mechanisms lock in place.

NOTE: There will be an audible click.

2. Pull on the handles to make sure the back is locked in place.

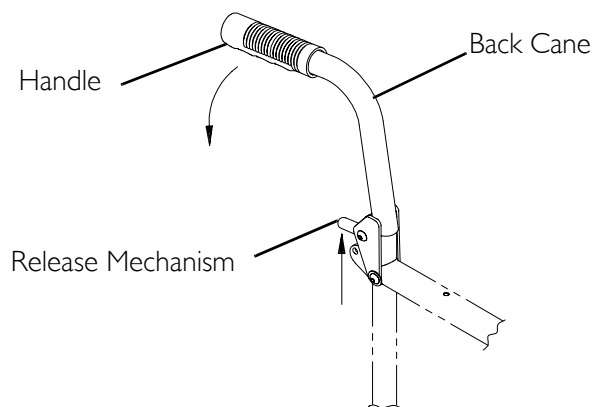

NOTE: Handle shown for the Transport and the Lightweight Transport.

FIGURE 5.1 Unfolding/Folding the Fold-Down Back

Replacing Back Upholstery

NOTE: For this procedure, refer to FIGURE 5.2.

1. Remove the screws and washers that secure the existing back upholstery to the back canes.
2. Position new back upholstery on back canes.
3. Securely tighten the new back upholstery to the back canes with the screws and washers.

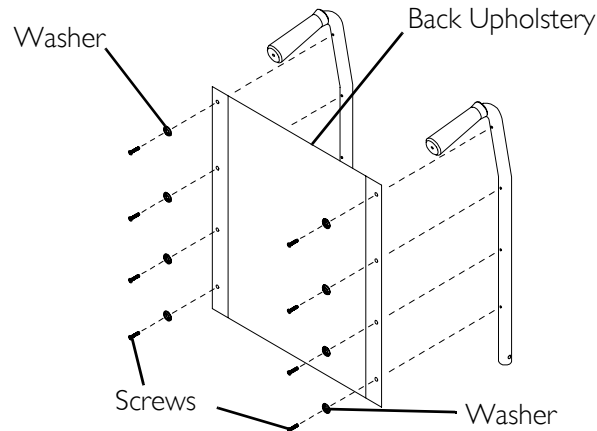

NOTE: Back upholstery shown is for the Transport and the Lightweight Transport. The Lite Transport has 10 screws and washers. The Bariatric Transport has 16 screws and washers.

FIGURE 5.2 Replacing Back Upholstery

Replacing Seat Upholstery

NOTE: For this procedure, refer to FIGURE 5.3.

1. Remove the screws that secure the existing seat upholstery to the crossbraces.
2. Remove the existing seat upholstery from the crossbraces.
3. Install the new seat upholstery by reversing STEPS 1-2.

NOTE: Seat upholstery shown is for the Transport, the Lightweight Transport, and the Lite Transport. The Bariatric Transport has 14

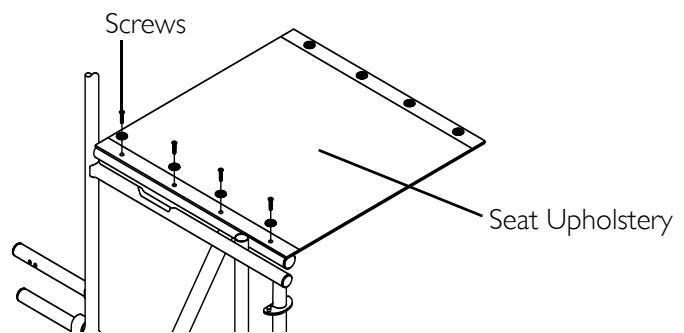

FIGURE 5.3 Replacing Seat Upholstery

SECTION 6—REAR WHEELS

⚠ WARNING

After any adjustments, repair or service and before use, make sure all attaching hardware is tightened securely. Otherwise, injury or damage could result.

CAUTION

As with any vehicle, the wheels and tires should be checked periodically for cracks and wear, and should be replaced.

Removing/Installing Rear Wheels

NOTE: For this procedure, refer to FIGURE 6.1.

1. Remove the dust cap (if applicable), hex screw and locknut that secure the rear wheel and axle spacer to the transport chair.
2. Repeat STEP 1 for the opposite rear wheel.
3. To reinstall the rear wheels onto the transport chair, reverse STEPS 1-2.

NOTE: Make sure the axle spacer is between the rear wheel and the transport chair frame.

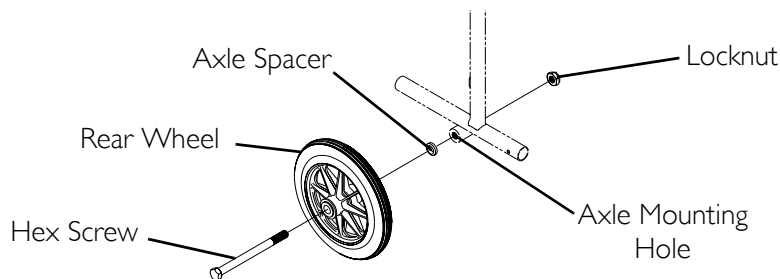

NOTE: Rear wheel shown for Invacare Transport and Lightweight Transport. Dust cap for Bariatric Transport and Lite Transport not shown.

FIGURE 6.1 Removing/Installing Rear Wheels

SECTION 7—CASTERS

⚠ WARNING

After any adjustments, repair or service and before use, make sure all attaching hardware is tightened securely - otherwise injury or damage may result.

CAUTION

As with any vehicle, the wheels and tires should be checked periodically for cracks and wear, and should be replaced when necessary.

Replacing/Adjusting Front Forks

NOTE: For this procedure, refer to FIGURE 7.1 on page 28.

Replacing

1. Remove the caster from the fork. Refer to [Replacing Front Casters](#) on page 28.
2. Remove the dust cover.
3. Remove the locknut and nylon washer that secure the fork to the caster headtube.
4. Drop the fork out of the caster headtube.
5. Slide the new fork into the caster headtube and reassemble by reversing STEPS 1-4.
6. Adjust the forks. Refer to [Adjusting](#) on page 27.
7. Repeat STEPS 1-6 for the opposite fork, if necessary.

Adjusting

1. Remove the dust cover.
2. To properly tighten the caster journal system and guard against flutter, perform the following check:
 - A. Tip back the transport chair to floor.
 - B. Simultaneously pivot both forks and casters to the top of their arc.
 - C. Let the casters drop to the bottom of the arc (wheels should swing once to one-side, then immediately rest in a straight downward position).
 - D. Adjust the locknuts according to freedom of the caster swing.
3. Test the transport chair for maneuverability.
4. Readjust the locknuts if necessary, and repeat STEPS 2-3 until correct.
5. Snap the dust cover over the locknut and stem.

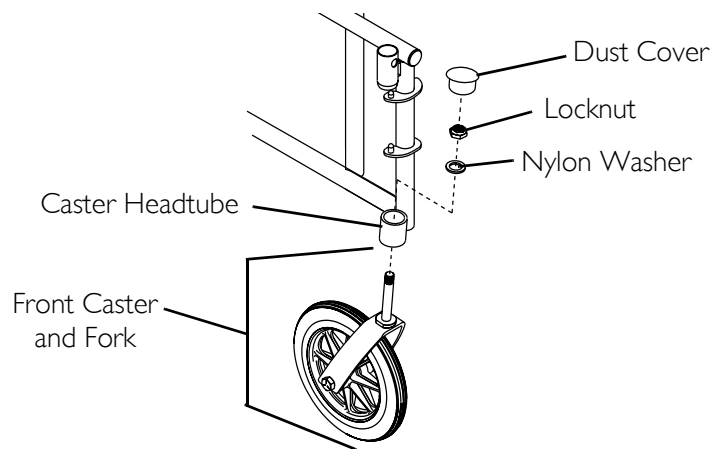
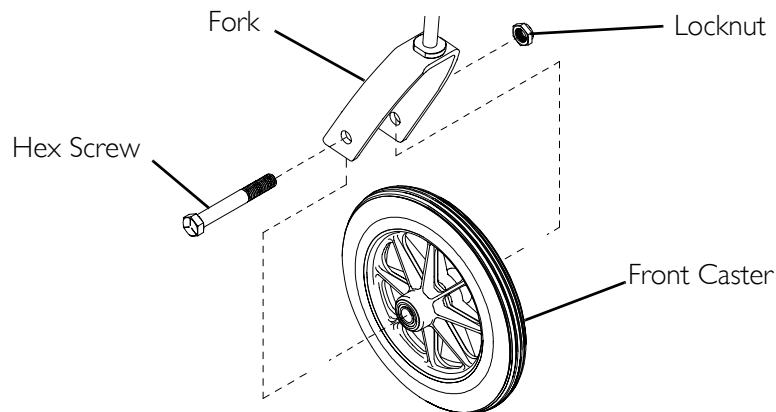

FIGURE 7.1 Replacing/Adjusting Front Forks

Replacing Front Casters

NOTE: For this procedure, refer to FIGURE 7.2.

1. Remove the hex screw, washers and locknut that secure the front caster to the fork.
2. Install the new front caster onto the transport chair by reversing STEP 1.
3. Repeat STEPS 1-2 for the opposite front caster if necessary.



NOTE: Dust cap not shown.

FIGURE 7.2 Replacing Front Casters

SECTION 8—HAND BRAKES/WHEEL LOCKS

⚠ WARNING

After any adjustments, repair or service and before use, make sure all attaching hardware is tightened securely. Otherwise, injury or damage may result.

DO NOT leave the Bariatric Transport on inclined surfaces. The wheel locks and hand brakes may not hold the Bariatric Transport on inclined surfaces due to the transport chair's increased weight capacity.

Wheel locks are not brakes. **DO NOT** attempt to stop a moving transport chair with the wheel locks.

Before attempting to transfer in or out of the transport chair, every precaution should be taken to reduce the gap distance. Turn both casters parallel to the object you are transferring onto. When transferring to and from the transport chair, **ALWAYS** engage both wheel locks. If the transport chair is equipped with hand brakes, **ALWAYS** lock both hand brakes before transferring to and from the transport chair.

Locking/Unlocking/Using Hand Brakes

NOTE: These procedures are applicable only to the Bariatric Transport and the Lite Transport.

Locking Hand Brake

NOTE: For this procedure, refer to FIGURE 8.1.

1. Push down on the bottom portion of the brake handle until an audible click is heard.
2. Refer to [Unlocking Hand Brake](#) on page 29.

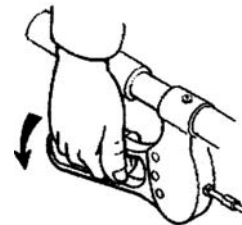

FIGURE 8.1 Locking Hand Brake

Unlocking Hand Brake

NOTE: For this procedure, refer to FIGURE 8.2.

1. Pull up on the top portion of the brake handle to release.
2. Release the brake handle.

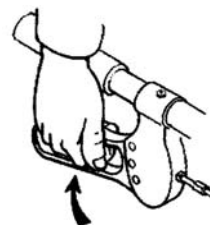

FIGURE 8.2 Unlocking Hand Brake - Using Hand Brake

Using Hand Brake

NOTE: For this procedure, refer to FIGURE 8.2 on page 29.

1. Pull up on the top portion of the brake handles toward the push handles.
2. Do one of the following:
 - Remain stationary - Hold the brake handle up.
 - Continue mobility - Release the brake handle.

Adjusting Hand Brakes

NOTE: This procedure is applicable only to the Bariatric Transport and the Lite Transport.

NOTE: Counterclockwise/clockwise directions are determined by standing behind the transport chair (user's position).

Adjusting Brake Handle

NOTE: For this procedure, refer to FIGURE 8.3.

Test the brake handle. Observe how the brake lever engages the wheel. If the tension of the brake is too loose or too tight, adjust using the following steps:

1. Loosen the brake handle adjustment nut by turning clockwise.
2. Perform one of the following:
 - Loosen brake handle tension - Turn the brake handle nut clockwise.
NOTE: If the brake lever is scraping the rear wheel, the brake handle must be loosened.
 - Tighten brake handle tension - Turn the brake handle nut counterclockwise.
NOTE: If the brake lever does not respond quickly, tighten brakes.
3. Turn the brake handle adjustment nut counterclockwise to secure in place.
4. Do one of the following:
 - Acceptable tension - Repeat STEPS 1 - 3 for the opposite side, if necessary.
 - Unacceptable tension - Refer to [Adjusting Cable Adjuster Unit](#) on page 31.

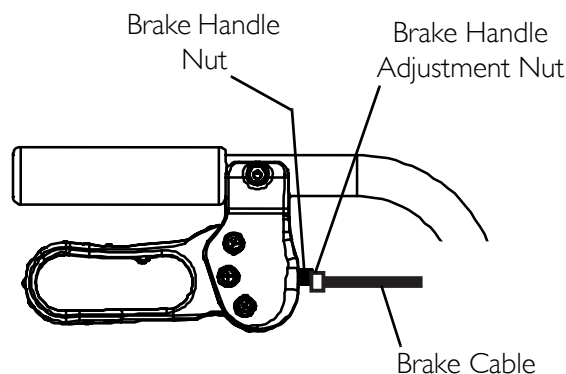

FIGURE 8.3 Adjusting Brake Handle

Adjusting Cable Adjuster Unit

NOTE: For this procedure, refer to FIGURE 8.4.

Test the brake with the brake handle. Observe how the brake lever engages the wheel. If the tension of the brake handle is still too loose or too tight, adjust using the following steps:

1. Ensure brake handle is not locked.
2. Do one of the following:
 - To Loosen: Brace the jam nut while turning the adjustment screw clockwise.
 - To Tighten: Brace the jam nut while turning the adjustment screw counterclockwise.
3. Repeat with other brake.

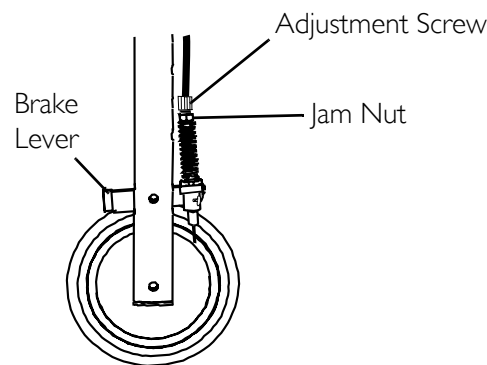

FIGURE 8.4 Adjusting Cable Adjuster Unit

Adjusting Wheel Lock

NOTE: For this procedure, refer to FIGURE 8.5 on page 32.

1. Loosen the bolt and locknut that secure the wheel lock assembly to the transport chair frame.
2. Adjust the position of wheel lock until the measurement between the rear wheel and the wheel lock shoe is between 5/32 and 5/16-inches.
3. Securely tighten the bolt and locknut.
4. Engage the wheel lock.
5. Push against the transport chair and determine if the wheel lock engages the wheel lock shoe enough to hold the transport chair.
6. Repeat the above procedures until the wheel lock holds the transport chair.
7. Repeat STEPS 1-6 for the opposite wheel lock.

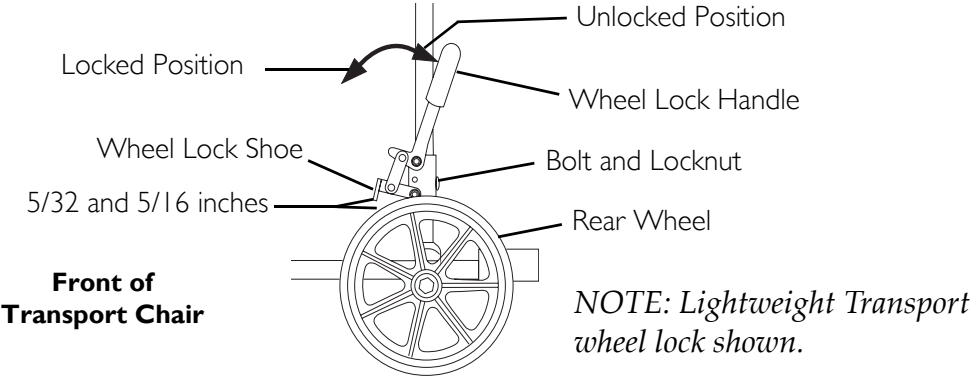

FIGURE 8.5 Adjusting Wheel Lock

NOTES

NOTES

LIMITED WARRANTY

PLEASE NOTE: THE WARRANTY BELOW HAS BEEN DRAFTED TO COMPLY WITH FEDERAL LAW APPLICABLE TO PRODUCTS MANUFACTURED AFTER JULY 4, 1975.

This warranty is extended only to the original purchaser who purchases this product when new and unused from Invacare or a dealer. This warranty is not extended to any other person or entity and is not transferable or assignable to any subsequent purchaser or owner. Coverage under this warranty will end upon any such subsequent sale or other transfer of title to any other person.

This warranty gives you specific legal rights and you may also have other legal rights which vary from state to state.

Invacare warrants the side frames and cross members of this product when purchased new and unused to be free from defects in materials and workmanship for a period of thirteen (13) months from the date of purchase from Invacare or a dealer, with a copy of the seller's invoice required for coverage under this warranty. Invacare warrants the upholstered materials (seat, back and armrests of the arm assembly) and remaining components of this product when purchased new and unused to be free from defects in materials and workmanship for a period of thirteen (13) months from date of purchase from Invacare or a dealer, with a copy of the seller's invoice required for coverage under this warranty. If within such warranty periods any such product shall be proven to be defective, such product shall be repaired or replaced, at Invacare's option. This warranty does not include any labor or shipping charges incurred in replacement part installation or repair of any such product. Invacare's sole obligation and your exclusive remedy under this warranty shall be limited to such repair and/or replacement.

For warranty service, please contact the dealer from whom you purchased your Invacare product. In the event you do not receive satisfactory warranty service, please write directly to Invacare at the address at the bottom of this page. Provide dealer's name, address, the product model number, date of purchase, indicate nature of the defect and, if the product is serialized, indicate the serial number. Do not return products to our factory without our prior consent.

LIMITATIONS AND EXCLUSIONS: THE FOREGOING WARRANTY SHALL NOT APPLY TO SERIAL NUMBERED PRODUCTS IF THE SERIAL NUMBER HAS BEEN REMOVED OR DEFACED, PRODUCTS SUBJECT TO NEGLIGENCE, ACCIDENT, IMPROPER OPERATION, MAINTENANCE OR STORAGE, PRODUCTS MODIFIED WITHOUT INVACARE'S EXPRESS WRITTEN CONSENT INCLUDING, BUT NOT LIMITED TO, MODIFICATION THROUGH THE USE OF UNAUTHORIZED PARTS OR ATTACHMENTS; PRODUCTS DAMAGED BY REASON OF REPAIRS MADE TO ANY COMPONENT WITHOUT THE SPECIFIC CONSENT OF INVACARE, OR TO A PRODUCT DAMAGED BY CIRCUMSTANCES BEYOND INVACARE'S CONTROL, AND SUCH EVALUATION WILL BE SOLELY DETERMINED BY INVACARE. THE WARRANTY SHALL NOT APPLY TO NORMAL WEAR AND TEAR OR FAILURE TO ADHERE TO THE PRODUCT INSTRUCTIONS.

THE FOREGOING EXPRESS WARRANTY IS EXCLUSIVE AND IN LIEU OF ANY OTHER WARRANTIES WHATSOEVER, WHETHER EXPRESS OR IMPLIED, INCLUDING THE IMPLIED WARRANTIES OF MERCHANTABILITY AND FITNESS FOR A PARTICULAR PURPOSE, AND THE SOLE REMEDY FOR VIOLATIONS OF ANY WARRANTY WHATSOEVER, SHALL BE LIMITED TO REPAIR OR REPLACEMENT OF THE DEFECTIVE PRODUCT PURSUANT TO THE TERMS CONTAINED HEREIN. THE APPLICATION OF ANY IMPLIED WARRANTY WHATSOEVER SHALL NOT EXTEND BEYOND THE DURATION OF THE EXPRESS WARRANTY PROVIDED HEREIN. INVACARE SHALL NOT BE LIABLE FOR ANY CONSEQUENTIAL OR INCIDENTAL DAMAGES WHATSOEVER.

SOME STATES DO NOT ALLOW THE EXCLUSION OR LIMITATION OF INCIDENTAL OR CONSEQUENTIAL DAMAGE, OR LIMITATION OF HOW LONG AN IMPLIED WARRANTY LASTS, SO THE ABOVE EXCLUSION AND LIMITATION MAY NOT BE APPLICABLE.

THIS WARRANTY SHALL BE EXTENDED TO COMPLY WITH STATE/PROVINCIAL LAWS AND REQUIREMENTS.



Yes, you can.

Invacare Corporation www.invacare.com

USA
One Invacare Way
Elyria, Ohio USA
44036-2125
800-333-6900

Canada
570 Matheson Blvd E Unit 8
Mississauga Ontario
L4Z 4G4 Canada
800-668-5324

All rights reserved. Trademarks are identified by [™] and [®].
All trademarks are owned by or licensed to Invacare Corporation unless otherwise noted.

© 2007 Invacare Corporation

Part No. I 125095

Rev D - 6/07